

microNexus™

380V – 480V

INSTALLATION GUIDE

FORM: SNUG-IG-E
REL. May 2023
REV. 001
© 2023 MTE Corporation



WARNING

High Voltage! Only a qualified electrician can carry out the electrical installation of this filter.

Quick Reference

1	How to Install	Pages 8 – 15
2	Start-up/Troubleshooting	Pages 16 – 20

This page intentionally left blank.

TABLE OF CONTENTS

1. SAFETY	4
WARNINGS AND CAUTIONS	4
GENERAL SAFETY INSTRUCTIONS	5
2. GENERAL INFORMATION	6
RECEIPT & REPAIR STATEMENT	6
ENCLOSURES	7
AGENCY APPROVALS	7
WARRANTY	7
3. HOW TO INSTALL	8
INSTALLATION CHECKLIST	8
DRIVE MOUNTING CAPABILITIES FOR ROCKWELL 520-SERIES VFDs.....	9
POWER WIRING CONNECTION	11
ENCLOSED UNIT INTERCONNECTION DIAGRAM	12
BASIC SCHEMATIC DIAGRAM	13
TRANSFORMER DIAGRAM	14
TERMINAL WIRE SIZING.....	15
4. START-UP	16
SAFETY PRECAUTIONS.....	16
5. TROUBLESHOOTING	18

List of Figures

Figure 3-1: Rockwell 520-Series Frame A & B Mounting Capabilities	9
Figure 3-2: Rockwell 520-Series Frame C & D Mounting Capabilities	9
Figure 3-3: Enclosed Interconnection.....	12
Figure 3-4: Basic Schematic Diagram.....	13
Figure 3-5: Transformer Diagram.....	14



List of Tables

Table 3-1: Overtemperature Switch.....	10
Table 3-2: Recommended Wire Size.....	15
Table 5-1: Performance Specifications.....	19
Table 5-2: Troubleshooting Guide.....	20



1. SAFETY

Warnings and Cautions

The following symbols are used in this manual:

 WARNING	High Voltage Warning: warns of situations that dangerously high voltage is involved. Failure to use proper precautions may lead to serious injury or death.
 WARNING	General Warning: warns of situations that can result in serious injury or death if proper precautions are not used.
 Caution	General Caution: identifies situations that could lead to malfunction or possible equipment damage.

General Safety Instructions

 WARNING	<p>High Voltage! Only a qualified electrician can carry out the electrical installation of this filter.</p>
	<p>High voltage is used in the operation of this filter. Use extreme caution to avoid contact with high voltage when operating, installing or repairing this filter. Injury or death may result if safety precautions are not observed.</p>
 WARNING	<p>The opening of the branch circuit protective device may be an indication that a fault current has been interrupted. To reduce the risk of fire or electrical shock, current-carrying parts and other components of the filter should be examined and replaced if damaged.</p>
	<p>An upstream disconnect/protection device must be used as required by the National Electrical Code (NEC) or governing authority.</p>
	<p>Even if the upstream disconnect/protection device is open, the drive downstream of the filter may feed back high voltage to the filter. The drive safety instructions must be followed. Injury or death may result if safety precautions are not observed.</p>
	<p>The filter must be grounded with a grounding conductor connected to all grounding terminals.</p>
	<p>Only spare parts obtained from MTE Corporation or an authorized MTE distributor can be used.</p>
	<p>After removing power, allow at least five minutes to elapse and verify that the capacitors have discharged to a safe level before removing wires from the terminal block. Connect a DC voltmeter across the capacitor terminals to ensure that the voltage is at a safe level.</p>
	<p>Review the schematic prior to connecting unit in DC Bus Configuration. Connecting the unit incorrectly could result in failure of drive and filter components.</p>
 Caution	<p>Loose or improperly secured connections may damage or degrade filter performance. Visually inspect and secure all electrical connections before power is applied to the filter.</p>
	<p>Prior to start-up; confirm the drive operation mode is property set (Volts per Hertz). Please consult drive manual/manufacturer to configure proper parameters. Failure to do so may result in failure of drive or filter components.</p>

2. GENERAL INFORMATION

The purpose of the manual is to aid in the proper installation of the microNexus.

For most current information, please refer to website:

<https://mtecorp.com/micronexus-motor-protection-filter/>

The microNexus filters transform the output of Variable Frequency Drives (VFDs) to a near perfect sinusoidal waveform for the best level of motor protection. MTE's unique design offers high performance in both differential and common mode with smaller size and better efficiency than traditional industry solutions.

Receipt & Repair Statement

Upon Receipt of this Filter:

The microNexus motor protection filter has been subjected to demanding factory tests before shipment. Carefully inspect the shipping container for damage that may have occurred in transit. Then unpack the filter and carefully inspect for any signs of damage. Save the shipping container for future transport of the filter.

In the event of damage, please contact and file a claim with the freight carrier involved immediately.

If the equipment is not going to be put into service upon receipt, cover and store the filter in a clean, dry location. After storage, ensure that the equipment is dry and that no condensation or dirt has accumulated on the internal components of the filter before applying power.

Repair/Exchange Procedure

MTE Corporation requires a Return Material Authorization Number and form before we can accept any filters that qualify for return or repair. If problems or questions arise during installation, setup, or operation of the filter, please contact MTE for assistance at:

Toll Free: 1-800-455-4MTE (1-800-455-4683)

International Tel: (+1) 262-253-8200

Fax: 262-253-8222

Enclosures

MTE enclosures are designed to provide a of protection for electrical components and prevent incidental personnel contact with the enclosed equipment.

An approximate cross reference guide between NEMA, UL, CSA and IEC enclosures follow.

IP20 Enclosure:

This touchproof enclosure is designed for indoor use only and will provide protection against solid objects up to 12mm. This enclosure does not provide protection against liquids.

Agency Approvals

UL and cUL listed to UL508 Type MX and CSA-C22.2 No 14-95
File E180243



Warranty

Five years from the date of shipment. See <http://www.mtecorp.com/industry-leading-warranty/> for details.

Five-year motor bearing warranty from the date of registration. See <https://mtecorp.com/sinewave-nexus-warranty/> for more information.

3. HOW TO INSTALL

Installation Checklist

 WARNING	<p>Prior to installation, please review the safety instructions on page 4 & 5. Failure to practice this can result in body injury!</p>
	<p>Input and output wiring to the filter should be performed by authorized personnel in accordance with NEC and all local electrical codes and regulations.</p>
 WARNING	<p>The filter is designed for use with copper conductors with a minimum temperature rating of 75°C.</p>

The microNexus will be provided in IP20 enclosed configurations. The compact enclosed style construction will use natural convection to control temperature rise.

Mounting Capabilities:

The microNexus motor protection filter is designed for mounting within the customer's enclosure and provides the ability to mount a Variable Frequency Drive (VFD) directly to the filter's enclosure. When determining the internal temperature rise and cooling requirements of the enclosure, include the power dissipation of the filter along with all the other components located in the panel. Avoid locations where the filter would be subjected to excessive vibrations. Locate the filter as close to the inverter as possible.

Each microNexus filter has the following mounting capabilities:

- The enclosure can be mounted vertically or horizontally to a panel or wall.
- The front of the enclosure, when mounted vertically, is compatible with mounting Rockwell PowerFlex 520-Series AC Drives directly to the filter.
 - RA Frame A & B drives compatible with the following microNexus P/Ns:
 - SNUG0002D
 - SNUG0003D
 - SNUG0005D
 - SNUG0007D
 - RA Frame C & D drives compatible with the following microNexus P/Ns:
 - SNUG0009D
 - SNUG0012D
 - SNUG0017D
 - SNUG0022D
 - Reference Figure 3-1 and Figure 3-2 (p9) for more information.
- Mounting capabilities for non-Rockwell Automation drives are available upon request. Please contact MTE for more information.
- When mounting a drive to the microNexus filter, you must refer to the drive manufacturer's minimum space requirements.

Drive Mounting Capabilities for Rockwell 520-Series VFDs

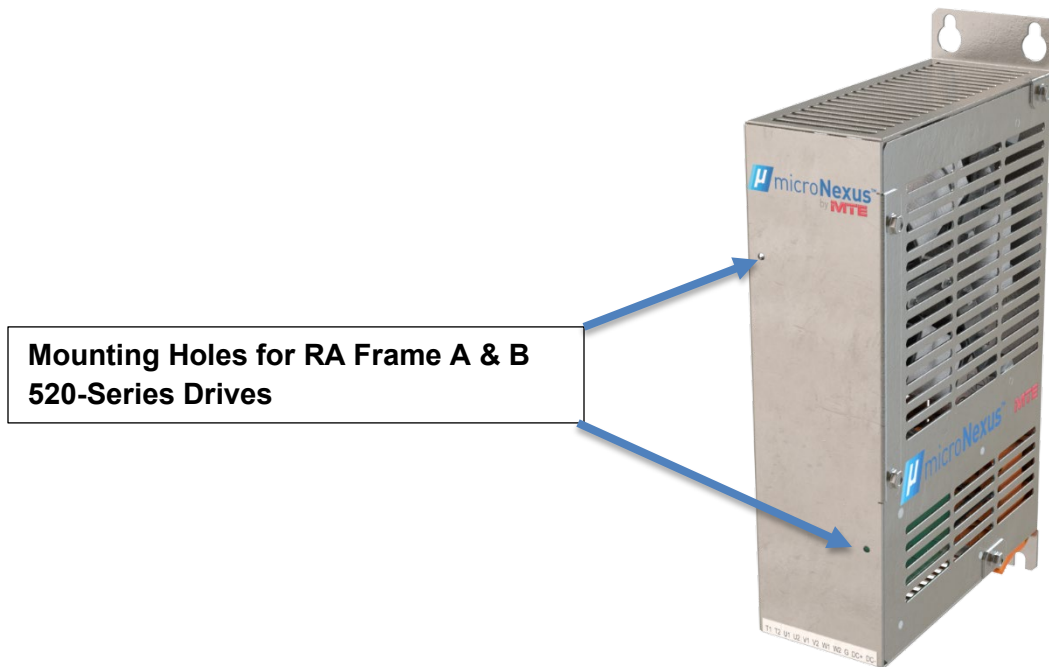

Figure 3-1: Rockwell 520-Series Frame A & B Mounting Capabilities

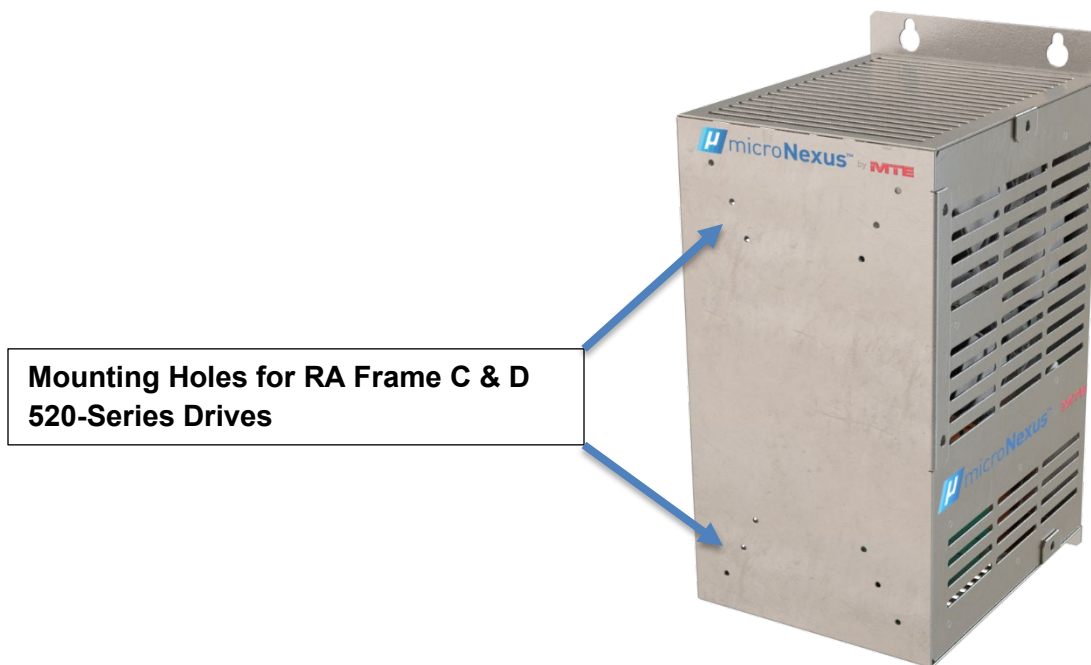

Figure 3-2: Rockwell 520-Series Frame C & D Mounting Capabilities

Grounding



The filter must always be grounded with a grounding conductor connected to ground terminals.

NOTE: For cable shield grounding follow the drive manufacturer's recommendations.

Grounding and Ground Fault Protection

Due to high leakage currents associated with variable frequency drives, ground fault protective devices do not necessarily operate correctly. When using this type of device, its function should be tested in the actual installation.

Overtemperature Interlock

An overtemperature interlock circuit should be used in conjunction with thermal switch to turn off the drive to prevent filter damage due to abnormal operating conditions. The temperature switch is normally closed and will open when an internal reactor temperature of 180°C is reached. See Table 3-1: Overtemperature Switch, below for contact rating information and the drive user manual for interconnection information.

Table 3-1: Overtemperature Switch

NC Switch opens at 180°C (+/- 5°C)		
Current Amps	Voltage	Contact Load
6	120 AC	Resistive Loads
3	120 AC	Inductive Loads
3	240 AC	Resistive Loads
2.5	240 AC	Inductive Loads
8	12 VDC	Resistive Loads
4	24 VDC	Resistive Loads

MTE highly recommends the use of the overtemperature switch to prevent damage to the filter in rare instances of overheating from abnormal operating conditions.

Power Wiring Connection

 WARNING	Input and output power wiring to the filter should be performed by authorized personnel in accordance with the NEC and all local electrical codes and regulations. Cable lugs and mounting hardware are provided by the customer.
	Any extremely low or high resistance readings indicate miswiring and may result in damage to filter components if not corrected.

Verify that the power source to which the filter is to be connected is in agreement with the nameplate data on the filter. A fused disconnect switch or circuit breaker should be installed between the drive and its source of power in accordance with the requirements of the NEC and all local electrical codes and regulations. Refer to the drive user manual for selection of the correct fuse rating and class.

The typical interconnection diagrams that follow are shown for a motor load, but the load can be either a motor or a transformer.

- Interconnection between the power source, VFD, MTE filter, and the motor is shown in Figure 3-1: Enclosed Interconnection (p12).
- Interconnection between the power source, VFD, MTE filter, transformer, and the motor is shown in Figure 3-3: Transformer Diagram (p14).

Wire gauge range requirements are shown in Table 3-2: Torque Ratings 380-480V (p15).

Refer to the drive user manual for instructions on interconnecting the drive and motor and the correct start-up procedures for the drive.

The filter is designed for use with copper conductors with a minimum temperature rating of 75°C.

Enclosed Unit Interconnection Diagram

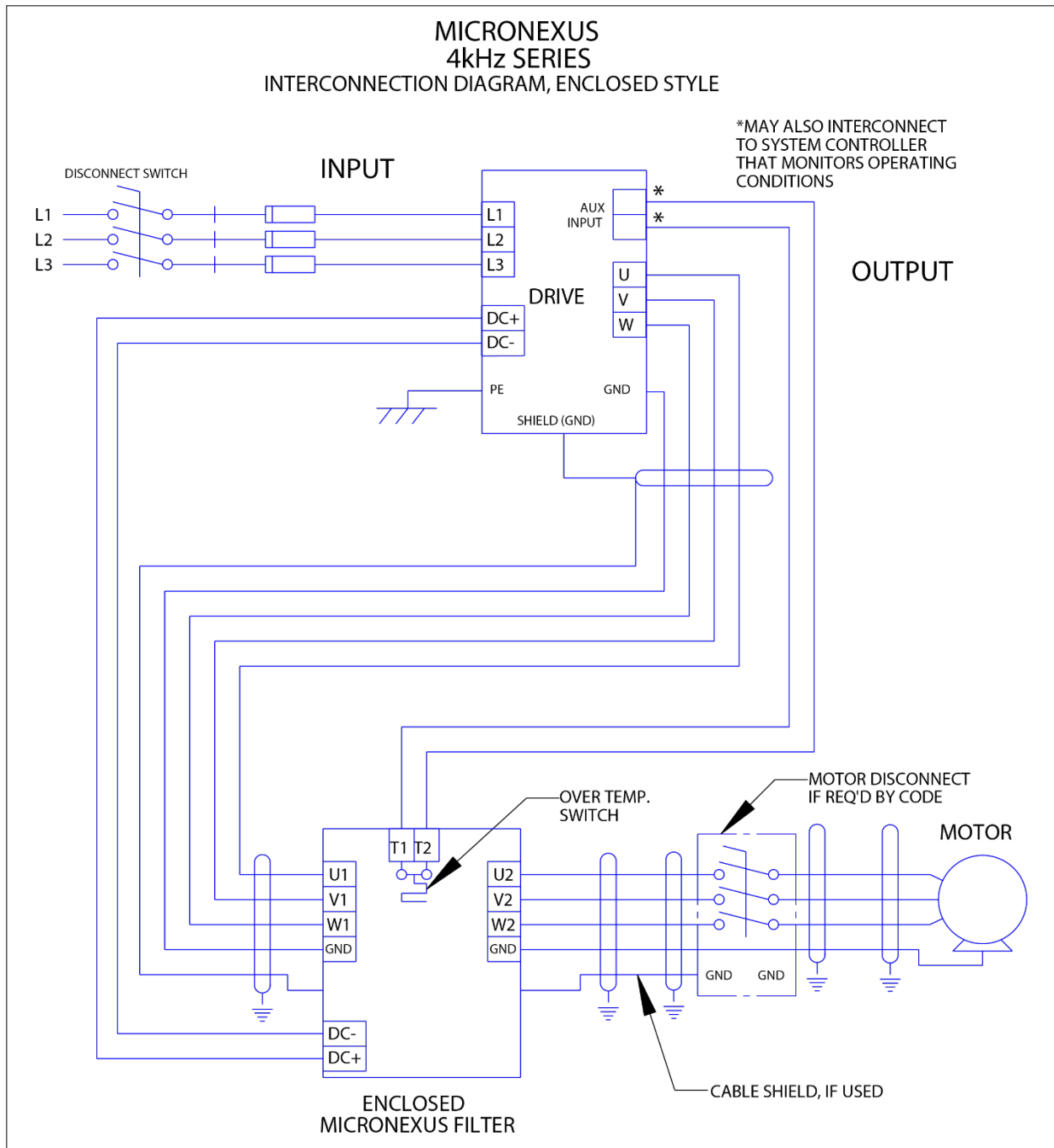

Figure 3-3: Enclosed Interconnection

Basic Schematic Diagram

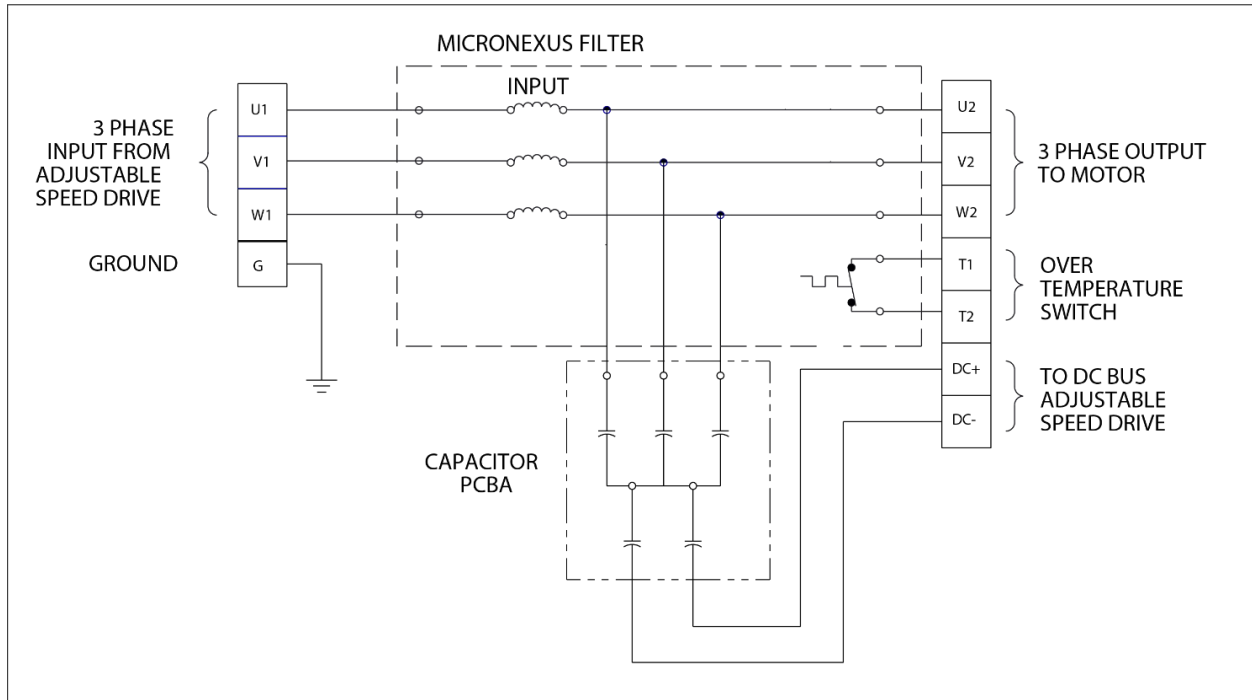

Figure 3-4: Basic Schematic Diagram

Transformer Diagram

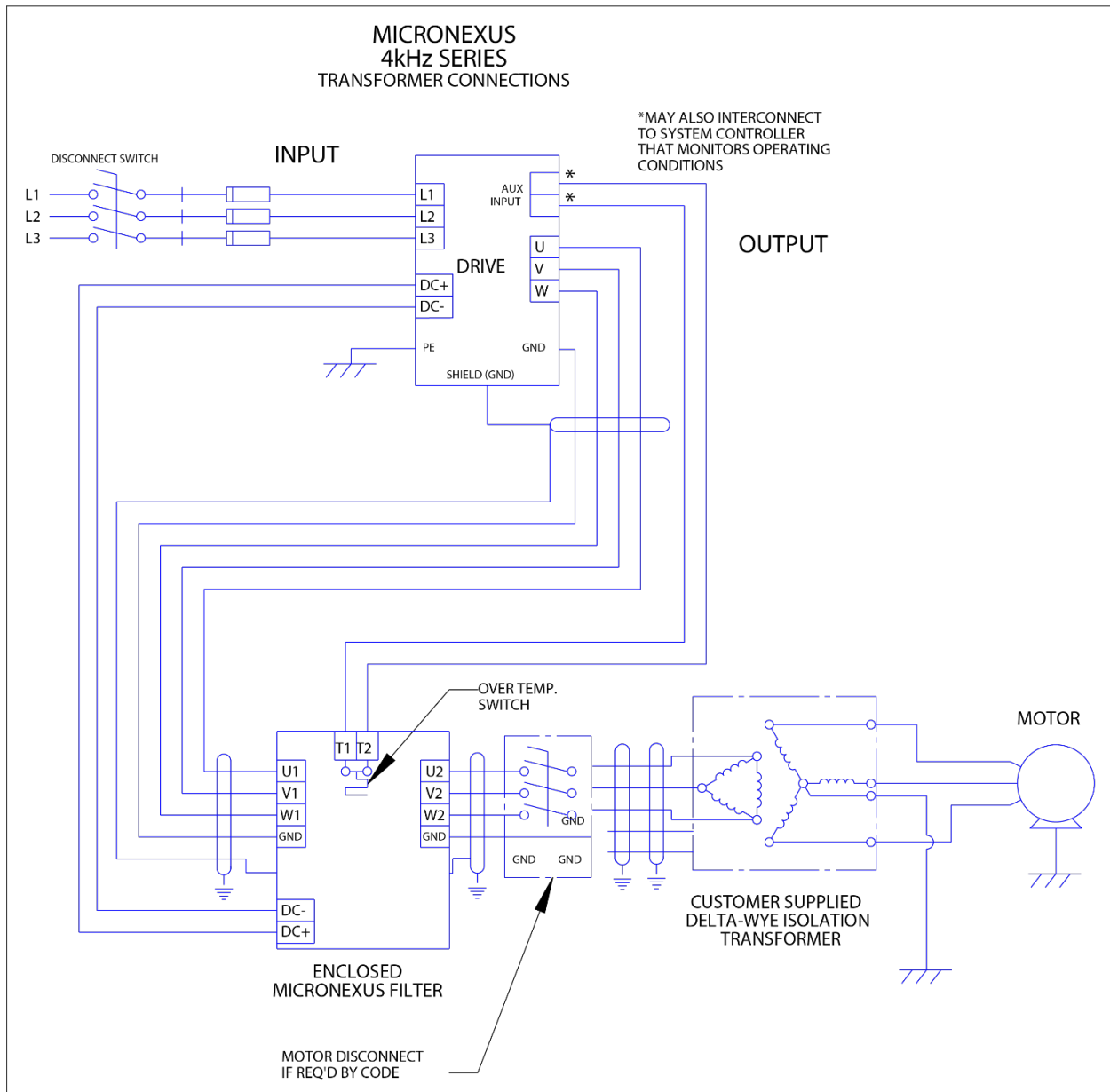

Figure 3-5: Transformer Diagram

Terminal Wire Sizing

Table 3-2: Recommended Wire Size

Filter Rating (Amps)	Input /Output Power U1-V1-W1 / U2-V2-W2
	Recommended Minimum Wire Size (AWG)
2	14
3	14
5	14
7	14
9	14
12	14
17	12
22	10



Notes:

1. Terminals are spring clamp style terminals.
2. When using stranded wire, use a 3.5mm flat screwdriver to open terminal prior to inserting wire.

4. START-UP

Safety Precautions



Before start-up, observe the following warnings and instructions:

 WARNING	<p>Internal components of the filter are at line potential when the filter is connected to the drive. This voltage is extremely dangerous and may cause death or severe injury if you come in contact with it.</p>
	<p>Remove all power to the SineWave filter in compliance to standardized 26 CFR 1920.147 lockout/tagout policies. After disconnecting the utility power, allow at least 5 minutes to elapse and verify that the capacitors have discharged to a safe level before removing wires from the terminal block. Connect a DC voltmeter across the capacitor terminals and ensure that the voltage is at a safe level.</p>
	<p>Use extreme caution to avoid contact with line voltage when checking for power. INJURY OR DEATH MAY RESULT IF SAFETY PRECAUTIONS ARE NOT OBSERVED.</p>
	<p>Review the schematic prior to connecting unit in DC Bus Configuration. Connecting the unit incorrectly could result in failure of drive and filter components.</p>
 Caution	<p>Prior to start-up; confirm the drive operation mode is properly set (Volts per Hertz). Please consult drive manual/manufacturer to configure proper parameters. Failure to do so may result in failure of drive or filter components.</p>
	<p>Damage to the filter may occur if the switching frequency is not set between 4 kHz and 8 kHz. Optimum switching frequency is at 4kHz and above.</p>
	<p>MTE recommends 10 seconds as an initial starting point for motor ramp time and that customers examine the actual inrush and ratings of their drive system. Inrush current seen at the drive from the filter that can easily be overcome by changing the motor ramp time.</p>

Sequence of Operation

1. Read and follow safety precautions.
2. After installation, ensure that:
 - a. All filter ground terminals are connected to ground.
 - b. Power wiring to the utility, drive, filter and motor is in accordance with the power wiring connection diagrams shown in installation instructions section.
3. Check that moisture has not condensed on the filter components. If moisture is present, do not proceed with start-up until the moisture has been removed.
4. Disconnect filter output terminals from the motor.
5. Set the drive switching frequency to 4 kHz. Refer to the drive user manual.
6. Connect filter temperature safety overload switch into the control circuit so that the drive will shut down in an overload situation.
7. Confirm that drive voltage is present at the input terminals (U1, V1, W1) of the filter.
8. Confirm that drive voltage is present at the output terminals (U2, V2, W2) of the filter.
9. Connect the filter output to the motor.
10. Refer to the drive user manual for the drive start-up procedure. Observe all safety instructions in the drive user manual.

5. TROUBLESHOOTING

 WARNING	<p>When properly installed, this equipment has been designed to provide maximum safety for operating personnel. However, hazardous voltages and elevated temperatures exist within the confines of the enclosure. Servicing should therefore be performed by qualified personnel only and in accordance with OSHA Regulations.</p>
	<p>High voltage is used in the operation of this filter. Use Extreme caution to avoid contact with high voltage when operating, installing or repairing this filter. INJURY OR DEATH MAY RESULT IF SAFETY PRECAUTIONS ARE NOT OBSERVED.</p>
 Caution	<p>After removing power, allow at least five minutes to elapse and verify that the capacitors have discharged to a safe level before contacting internal components. Connect a DC voltmeter across output terminals U2 and V2 or V2 and W2 and ensure that the voltage is at a safe level.</p>

To aid in troubleshooting, a basic schematic diagram, interconnection diagrams, and a troubleshooting guide that lists potential problems and solutions are included:

Figure 3-3: Enclosed Interconnection (p12)

Figure 3-4: Basic Schematic Diagram (p13)

Figure 3-5: Transformer Diagram (p14)

Table 5-2: Troubleshooting Guide (p20)

Table 5-1: Performance Specifications

Service Load Condition	Conventional 3 phase motors operating in volts per Hertz mode Standard step-up or delta-wye transformer
Voltage	380-480V +/- 10%
Input Voltage Wave Form	PWM
Harmonic Voltage Distortion	5% maximum @ 4kHz
Common Mode Attenuation	-20dB (>90% PWM common mode RMS voltage reduction) @ 4kHz
Inverter Switching Frequency	4kHz
Inverter Operating Frequency	6Hz to 75Hz, >75Hz to 120Hz with derating
Maximum Ambient Temperature	-40°C to +40°C Enclosed Filter -40°C to +90°C Storage
Insulation System	Class N (200°C)
Insertion Loss (Voltage)	10% maximum @ 60Hz
Efficiency	>98%
Altitude without derating	3,300 feet above sea level
Maximum Motor Lead Length	15,000 feet
Relative Humidity	0% to 95% non-condensing
Current Rating	100% RMS Continuous 150% for 1 minute Intermittent
Audible Noise	75dBA at 1 meter

NOTE: Filter does not mitigate any DC bus ripple that may be present, or 3rd order harmonics injected by the drive.

Table 5-2: Troubleshooting Guide

PROBLEM: Drive Overcurrent Fault	
Possible cause:	Motor ramp-up time too short.
Solution:	MTE suggests a ramp time of >5-10 seconds. Consult drive manufacturers manual to configure proper parameters.
Possible cause:	Failed or incorrect wiring
Solution:	Verify all field and product wiring is correct.
Possible cause:	Parameter compatibility.
Solution:	Consult drive manufacturer's manual for operating drive with a motor protection filter.
Possible cause:	Filter, Drive, Motor current ratings incompatible.
Solution:	Verify the filter and motor are properly sized for the application.
Possible cause:	Drive not configured for Volts/ Hertz.
Solution:	Consult drive manufacturers manual to configure proper parameters.
Possible cause:	Motor winding fault.
Solution:	Verify motor windings and hi-pot is necessary.
Possible cause:	Cable failure.
Solution:	Verify cable continuity and insulation.
PROBLEM: Excessive Filter Noise	
Possible cause:	Mismatched motor rating.
Solution:	Verify the filter is properly sized for the application.
Possible cause:	Carrier frequency less than 2 kHz.
Solution:	Verify the carrier frequency is at least 2 kHz.
PROBLEM: Temperature Switch Open	
Possible cause:	Mismatched motor rating.
Solution:	Verify the filter is properly sized for the application.
Possible cause:	Carrier frequency less than 4 kHz.
Solution:	Verify the carrier frequency is at least 4 kHz.
Possible cause:	Excessive ambient temperature.
Solution:	Ensure filter is operating within specified ambient temperature below 60°C.
PROBLEM: Motor will not turn.	
Possible cause:	No power.
Solution:	Check fuses or breakers for proper input power.
Possible cause:	Motor incorrectly wired.
Solution:	Check for wiring faults.
Possible cause:	Locked rotor motor load.
Solution:	Check motor load.
Possible cause:	Drive fault.
Solution:	Consult drive manufacturers manual.
Possible cause:	Overloaded motor.
Solution:	Verify the motor is properly sized for the application.