



High Frequency SineWave Guardian™ Filter

380V – 480V

TECHNICAL REFERENCE MANUAL



High Voltage! Only a qualified electrician can carry out the electrical installation of this filter.

❶	Performance Data	Pages 5 - 8
❷	Selection Guide	Pages 9 - 11
❸	Installation Guide	Pages 13 - 19
❹	Start-up/Troubleshooting	Pages 22 - 25

This page intentionally left blank

TABLE OF CONTENTS

1. SAFETY	1
WARNINGS AND CAUTIONS	1
GENERAL SAFETY INSTRUCTIONS	2
2. GENERAL INFORMATION	3
RECEIPT & REPAIR STATEMENT	3
AGENCY APPROVALS	4
WARRANTY	4
3. HIGH FREQUENCY SINEWAVE GUARDIAN PERFORMANCE DATA.....	5
PERFORMANCE SPECIFICATIONS	5
FILTER EFFICIENCY & WATT LOSS	6
VOLTAGE WAVEFORMS	7
ALTITUDE DERATING.....	8
4. HOW TO SELECT.....	9
SELECTION GUIDE	9
UNDERSTANDING THE HIGH FREQUENCY SINEWAVE GUARDIAN PART NUMBER	10
PART NUMBER SELECTION TABLES.....	11
5. HOW TO INSTALL.....	13
INSTALLATION CHECKLIST	13
POWER WIRING CONNECTION	15
MODULAR UNIT INTERCONNECTION DIAGRAM.....	16
BASIC SCHEMATIC DIAGRAM	17
ISOLATION TRANSFORMER DIAGRAM.....	18
TORQUE RATINGS	19
6. START-UP	22
SAFETY PRECAUTIONS.....	22
7. TROUBLESHOOTING.....	24

List of Figures

Figure 3-1: Output Voltage before High Frequency SineWave Filters	7
Figure 3-2: Output Voltage after High Frequency SineWave Filters	7
Figure 3-3: Altitude Derating Curve	8
Figure 5-1: Modular Interconnection	16
Figure 5-2: Basic Schematic Diagram.....	17
Figure 5-3: Isolation Transformer.....	18

List of Tables

Table 3-1: Performance Specifications	5
Table 3-2: Filter Efficiency & Watt Loss - *Based on 200Hz output frequency,	6
Table 3-3: Filter Efficiency & Watt Loss - *Based on *240Hz output frequency,.....	6
Table 3-4: Filter Efficiency & Watt Loss – Based on *300Hz output frequency,	6
Table 4-1: Modular Selection Table for 2kHz	11
Table 4-2: Modular Selection Table for 3.5kHz	11
Table 4-3: Modular Selection Table for 5kHz	12
Table 5-1: Overtemperature Switch	14
Table 5-2: Torque Ratings for 2kHz.....	19
Table 5-3: Torque Ratings for 3.5kHz.....	20
Table 5-4: Torque Ratings for 5kHz.....	21
Table 7-1: Troubleshooting Guide	25

1. SAFETY

Warnings and Cautions

The following symbols are used in this manual:

	High Voltage Warning: warns of situations that dangerously high voltage is involved. Failure to use proper precautions may lead to serious injury or even death.
WARNING	
	General Warning: warns of situations that can result in serious injury or death if proper precautions are not used.
WARNING	
	General Caution: identifies situations that could lead to malfunction or possible equipment damage.
Caution	

General Safety Instructions

	<p>High Voltage! Only a qualified electrician can carry out the electrical installation of this filter.</p>
WARNING	<p>High voltage is used in the operation of this filter. Use Extreme caution to avoid contact with high voltage when operating, installing or repairing this filter. Injury or death may result if safety precautions are not observed.</p>
	<p>The opening of the branch circuit protective device may be an indication that a fault current has been interrupted. To reduce the risk of fire or electrical shock, current-carrying parts and other components of the filter should be examined and replaced if damaged.</p>
	<p>An upstream disconnect/protection device must be used as required by the National Electrical Code (NEC) or governing authority.</p>
	<p>Even if the upstream disconnect/protection device is open, the drive down stream of the filter may feed back high voltage to the filter. The drive safety instructions must be followed. Injury or death may result if safety precautions are not observed.</p>
WARNING	<p>The filter must be grounded with a grounding conductor connected to all grounding terminals. Modular filters must have reactor grounded through a 2"x2" area cleaned of paint and varnish on lower mounting bracket.</p>
	<p>Only spare parts obtained from MTE Corporation or an authorized MTE distributor can be used.</p>
	<p>After removing power, allow at least five minutes to elapse and verify that the capacitors have discharged to a safe level before contacting internal components. Connect a DC voltmeter across the capacitor terminals and ensure that the voltage is at a safe level.</p>
Caution	<p>Loose or improperly secured connections may damage or degrade filter performance. Visually inspect and secure all electrical connections before power is applied to the filter.</p>
	<p>Prior to start-up; confirm the drive operation mode is property set (Volts per Hertz). Please consult drive manual/manufacturer to configure proper parameters. Failure to do so may result in failure of drive or filter components.</p>
	<p>Damage to the filter may occur if the output frequency is not set between 4.8 kHz and 8 kHz. Optimum output frequency is 5kHz.</p>
	<p>Over speeding a motor can cause it to break. Motor must be rated to run above 60Hz</p>

2. GENERAL INFORMATION

The purpose of the manual is to properly specify, size, and install the High Frequency SineWave filter.

High Frequency SineWave filters transform the output of Variable Frequency Drives (VFDs) to a near perfect sinusoidal waveform for the best level of motor protection. MTE's unique, patent-pending design offers high performance with smaller size and better efficiency than traditional LC filters.

For most current information, please refer to website

<http://www.mtecorp.com/products/sinewave-filters/high-frequency-sinewave-guardian/>

Receipt & Repair Statement

Upon Receipt of this Filter:

The High Frequency SineWave motor protection filter has been subjected to demanding factory tests before shipment. Carefully inspect the shipping container for damage that may have occurred in transit. Then unpack the filter and carefully inspect for any signs of damage. Save the shipping container for future transport of the filter.

In the event of damage, please contact and file a claim with the freight carrier involved immediately.

If the equipment is not going to be put into service upon receipt, cover and store the filter in a clean, dry location. After storage, ensure that the equipment is dry and that no condensation or dirt has accumulated on the internal components of the filter before applying power.

Repair/Exchange Procedure

MTE Corporation requires a Return Material Authorization Number and form before we can accept any filters that qualify for return or repair. If problems or questions arise during installation, setup, or operation of the filter, please contact MTE for assistance at:

Toll Free: 1-800-455-4MTE (1-800-455-4683)

International Tel: (+1) 262-253-8200

Fax: 262-253-8222

Agency Approvals

UL and cUL listed to UL508 Type MX and CSA-C22.2 No 14-95, File E180243, CE

Warranty

Three years from the date of shipment. For details please see:
<http://www.mtecorp.com/industry-leading-warranty/>

3. High Frequency SineWave Guardian Performance Data Performance Specifications

Table 3-1: Performance Specifications

Service Load Condition	Conventional 3 phase motors operating in volts per Hertz mode Standard step-up transformer or design for use of filter in sensor less vector mode.
Voltage	380V - 480V +/- 10%
Input Voltage Wave Form	PWM
Harmonic Voltage Distortion	8% maximum @ 2kHz 8% maximum @ 3.5kHz 8% maximum @ 6-8 kHz 5% maximum @ 5kHz
Inverter Switching Frequency*	2kHz 3.5kHz 4.8kHz – 8kHz
Inverter Operating Frequency*	0Hz - 200Hz @ 2kHz 0Hz - 240Hz @ 3.5kHz 0Hz - 300Hz @ 5kHz
Maximum Ambient Temperature	-40C to +60C Modular filter -40C to +90C Storage Temperature
Insulation System	Class N (200° C)
Insertion Loss (480V system voltage)	2kHz Filters 6% maximum @ 100Hz 12% maximum @ 200Hz
	3.5kHz Filters 6% maximum @ 150Hz 12% maximum @ 240Hz
	5kHz Filters 6% maximum @ 150Hz 12% maximum @ 300Hz
Efficiency	>99%
Current range	80A – 1200A
Available form factors	Modular
Altitude without derating	3,300 feet above sea level
Maximum Motor Lead Length	15,000 feet
Relative Humidity	0% to 95% non-condensing
Current Rating	100% RMS Continuous 150% for 1 minute Intermittent
Audible Noise	75dB A at 1 meter

*Additional ratings available upon request.

NOTE: Filter does not mitigate any DC bus ripple that may be present.

Filter Efficiency & Watt loss

**Table 3-2: Filter Efficiency & Watt Loss - *Based on 200Hz output frequency,
 2kHz carrier frequency at full load.**

Maximum Output Amps RMS/Filter Current Rating Amps RMS	Efficiency (%)	Typical Power Dissipation (Watts*)
200	99.6%	424
250	99.6%	1019
305	99.6%	1363
415	99.7%	1616
515	99.7%	2300
650	99.7%	2806
1000	99.7%	3602
1200	99.7%	4103

**Table 3-3: Filter Efficiency & Watt Loss - *Based on *240Hz output frequency,
 3.5kHz carrier frequency at full load.**

Maximum Output Amps RMS/Filter Current Rating Amps RMS	Efficiency (%)	Typical Power Dissipation (Watts*)
200	99.6%	850
250	99.6%	1058
305	99.6%	1079
415	99.7%	1267
515	99.7%	1477
650	99.7%	1865

**Table 3-4: Filter Efficiency & Watt Loss – Based on *300Hz output frequency,
 5kHz carrier frequency at full load**

Maximum Output Amps RMS/Filter Current Rating Amps RMS	Efficiency (%)	Typical Power Dissipation (Watts*)
80	99.5%	360
110	99.5%	451
130	99.5%	504
160	99.6%	563
200	99.6%	718
250	99.6%	911
305	99.6%	958
415	99.7%	1144
515	99.7%	1250
650	99.7%	1321

Voltage Waveforms

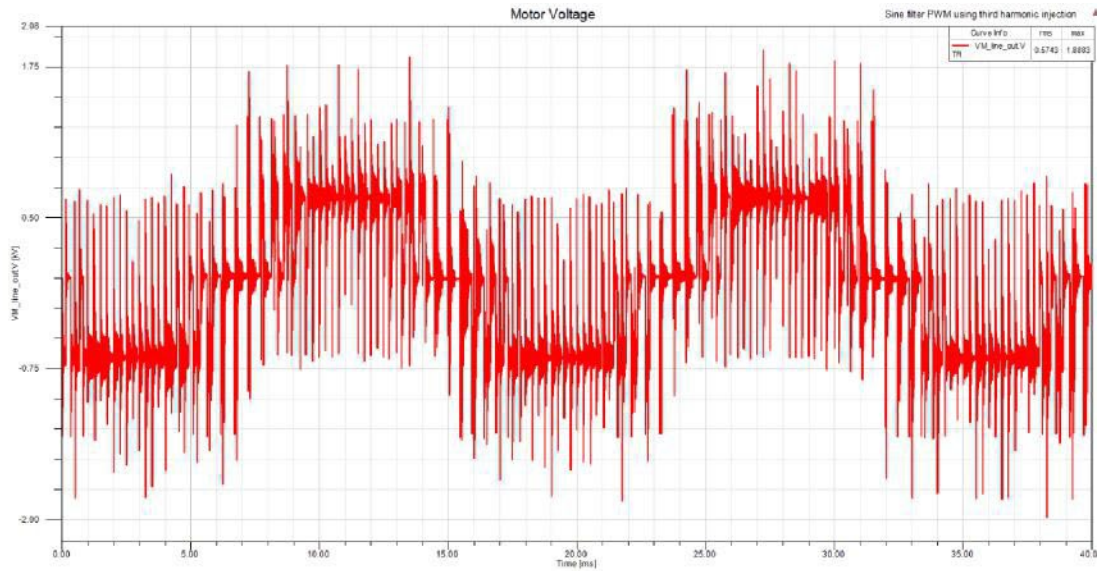

Figure 3-1: Output Voltage before High Frequency SineWave Filters

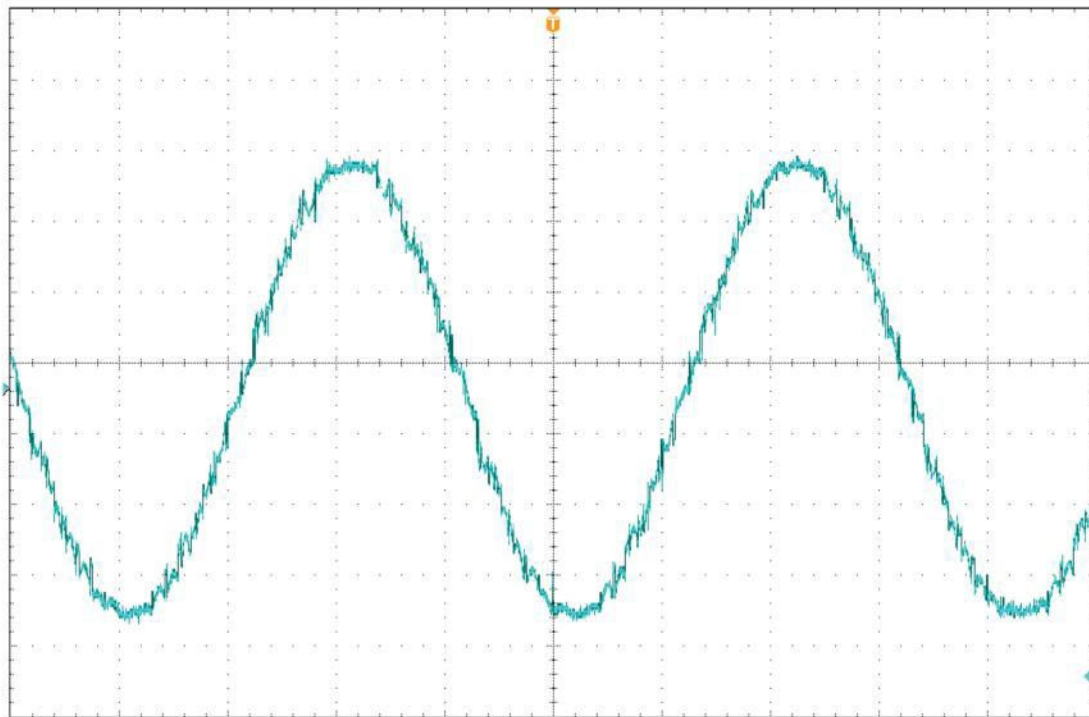
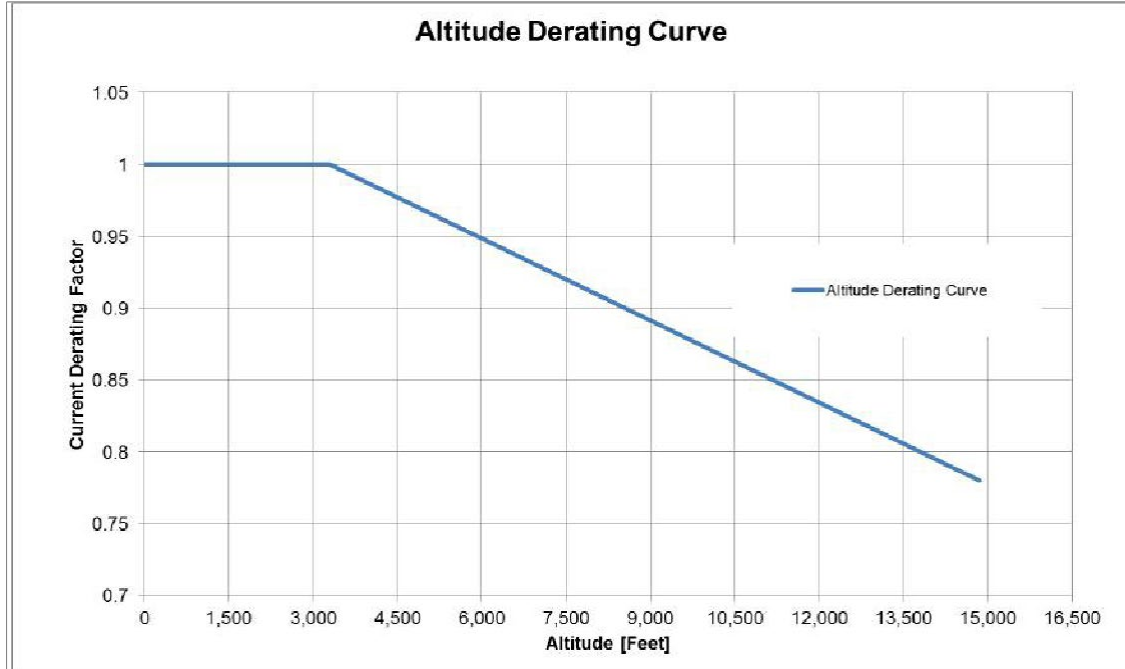

Figure 3-2: Output Voltage after High Frequency SineWave Filters

Altitude Derating

Figure 3-3: Altitude Derating Curve



4. HOW TO SELECT Selection Guide

MTE's High Frequency SineWave Guardian™ filters are designed to provide a sine wave output voltage when driven from PWM inverters with switching frequencies from 2kHz to 8kHz. For drive applications, these filters eliminate the problem of motor insulation failures and they also reduce electromagnetic interference by eliminating the high line-load dV/dt associated with inverter output waveforms.

High Frequency SineWave filters are available in Modular configuration. For other configurations call MTE.

For inverters feeding isolation transformers select a filter with a current rating equal to or greater than that of the transformer primary current.

Please verify information below for proper selection:

- Voltage:** Input voltage from 380V – 480V. See Table 3-1: Performance Specifications (p5) for specification.
- Current Rating:** Support for 80 Amps – 650 Amps.
- Switching Frequency:** Support for carrier frequency of 2kHz – 8kHz, see Table 3-1: Performance Specifications (p5).
- Drive Output Frequency:** Support for 6Hz to 300Hz without derating
- Temperature:** Maximum ambient temperature, 60C (modular). See Table 3-1: Performance Specifications (p5) for specification.
- Altitude:** 3,300 feet above sea level without derating. See Figure 3-3: Altitude Derating Curve (p8) for derating curve.
- Verify the drive output can be configured to Volts per Hz mode or that the drive is designed for use with filter in sensor less vector mode.
- Refer to Article 430 Table 430.91 of the National Electrical code for the selection of the appropriate enclosure Type Number for your application.

Understanding the High Frequency SineWave Guardian Part Number

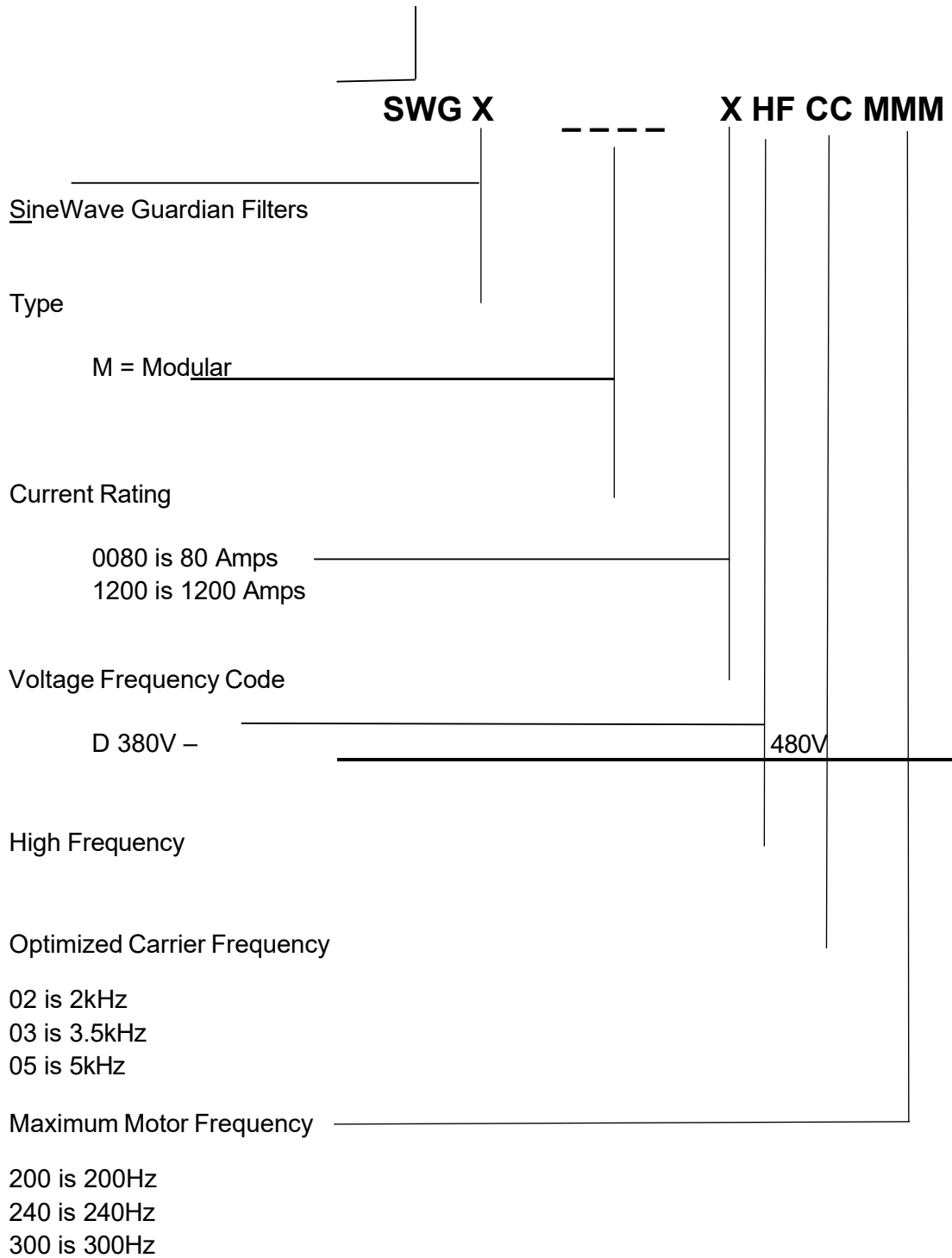

Part Number Selection Tables

Table 4-1: Modular Selection Table for 2kHz

380V Motor KW	480V Motor HP	Filter Amp Rating	Part Number	App. Wt. (lbs.)	Modular Magnetics (in.) (H x W x D)	3-Phase Capacitor Panel (in.) (H x W x D)
110	150	200	SWGM0200D-HF02200	225	12.2 x 15.3 x 12.8	6.7 x 16.4 x 7.6
132	200	250	SWGM0250D-HF02200	285	15.3 x 15.3 x 14.7	7.4 x 16.4 x 7.6
160	250	305	SWGM0305D-HF02200	352	15.9 x 15.3 x 15.7	7.4 x 16.4 x 7.6
220	350	415	SWGM0415D-HF02200	455	18.1 x 24.0 x 14.1	9.9 x 16.4 x 7.6
280	450	515	SWGM0515D-HF02200	776	18.3 x 24.0 x 17.4	7.42 x 16.4 x 7.6
375	600	650	SWGM0650D-HF02200	928	18.3 x 224.0 x 20.1	7.4 x 16.4 X 7.6
560	850	1000	SWGM0100D-HF02200	902	20.3 x 24.0 x 18.3 IN	7.6 x 16.3 x 8.3 IN & 7.6 x 16.3 x 9.9 IN
675	1000	1200	SWGM1200D-HF02200	795	20.1 x 24.0 x 19.1 IN	7.6 x 16.3 x 8.3 IN & 7.6 x 16.3 x 8.3 IN

Table 4-2: Modular Selection Table for 3.5kHz

380V Motor KW	480V Motor HP	Filter Amp Rating	Part Number	App. Wt. (lbs.)	Modular Magnetics (in.) (H x W x D)	3-Phase Capacitor Panel (in.) (H x W x D)
110	150	200	SWGM0200D-HF03240	139	12.3 x 15.3 x 11.2	7.4 x 16.4 x 7.6
132	200	250	SWGM0250D-HF03240	149	12.5 x 15.3 x 11.3	6.7 x 16.4 x 7.6 & 5.8 x 16.4 x 7.6
160	250	305	SWGM0305D-HF03240	180	12.5 x 15.3 x 12.3	6.7 x 16.4 x 7.6 & 5.8 x 16.4 x 7.6
220	350	415	SWGM0415D-HF03240	254	12.4 x 15.3 x 14.3	6.7 x 16.4 x 7.6
280	450	515	SWGM0515D-HF03240	262	14.4 x 15.3 x 13.1	7.4 x 16.4 x 7.6
375	600	650	SWGM0650D-HF03240	310	14.5 x 15.3 x 14.3	7.4 x 16.4 x 7.6

Table 4-3: Modular Selection Table for 5kHz

380V Motor KW	480V Motor HP	Filter Amp Rating	Part Number	App. Wt. (lbs.)	Modular Magnetics (in.) (H x W x D)	3-Phase Capacitor Panel (in.) (H x W x D)
37	60	80	SWGM0080D-HF05300	62	10.5 x 12.0 x 9.1	5.8 x 16.3 x 7.6
55	75	110	SWGM0110D-HF05300	78	10.1 x 12.0 x 10.1	5.8 x 16.3 x 7.6
-	100	130	SWGM0130D-HF05300	92	10.2 x 12.0 x 11.5	5.8 x 16.3 x 7.6
75	125	160	SWGM0160D-HF05300	96	10.0 x 12.0 x 11.6	5.8 x 16.3 x 7.6
110	150	200	SWGM0200D-HF05300	136	12.1 x 15.3 x 11.2	6.7 x 16.3 x 7.6
132	200	250	SWGM0250D-HF05300	143	12.3 x 15.3 x 11.3	6.7 x 16.3 x 7.6
160	250	305	SWGM0305D-HF05300	174	12.4 x 15.3 x 12.6	6.7 x 16.3 x 7.6
220	350	415	SWGM0415D-HF05300	244	12.3 x 15.3 x 14.3	(2) 6.7 x 16.3 x 7.6
280	450	515	SWGM0515D-HF05300	258	14.2 x 15.3 x 13.1	(3) 6.7 x 16.3 x 7.6
335	500	600	SWGM0600D-HF05300	306	14.3 x 15.3 x 14.3	(3) 6.7 x 16.3 x 7.6

5. HOW TO INSTALL Installation Checklist

	Prior to installation, please refer to all general warnings on pages 1 & 2. Failure to practice this can result in body injury!
WARNING	Input and output wiring to the filter should be performed by authorized personnel in accordance with NEC and all local electrical codes and regulations.
WARNING	The filter is designed for use with copper conductors with a minimum temperature rating of 75 degrees C.

High Frequency SineWave Guardian filters are supplied in the following mechanical configuration:

- **Modular:** Modular units consist of a reactor and one or more capacitor panel assemblies referred to as cap-panels on drawings and diagrams. Additional wiring between the reactor and capacitor/capacitor panel is required by customer.

Minimum Required Space:

Modular High Frequency SineWave Guardian filters are designed for mounting within the customer’s enclosure. When determining the internal temperature rise and cooling requirements of the enclosure, include the power dissipation of the filter along with all the other components located in the panel. A general guideline is to allow a side clearance of four (4) inches and a vertical clearance of six (6) inches for proper heat dissipation and access within the enclosure. Clearances may be less if proper ventilation exists. Filter components must operate within temperatures specified in this manual or filter operating life will be compromised. Also, be aware of minimum electrical clearances as defined by the appropriate system safety standard(s). These filters generate heat and should be positioned away from heat sensitive components. Avoid locations where the filter would be subjected to excessive vibrations. Locate the filter as close to the inverter as possible.

NOTE: Locate the capacitor panel in the lowest temperature regions of the enclosure – generally toward the bottom and away from high temperature components.

Grounding

	The filter must always be grounded with a grounding conductor connected to ground terminals.
WARNING	For modular units, ensure a 2" X 2" area is cleaned of paint and varnish on lower mounting bracket for ground connection.

NOTE: For cable shield grounding follow the drive manufactures recommendations.

Grounding and Ground Fault Protection

Due to high leakage currents associated with variable frequency drives, ground fault protective devices do not necessarily operate correctly when placed ahead of a SineWave Guardian filter feeding a drive. When using this type of device, its function should be tested in the actual installation.

Overtemperature Interlock

An overtemperature interlock circuit should be used in conjunction with thermal switch to turn off the drive to prevent filter damage due to abnormal operating conditions. The temperature switch is normally closed and will open when an internal reactor temperature of 180°C is reached. See Table 5-1: Overtemperature Switch below for contact rating information and the drive user manual for interconnection information.

Table 5-1: Overtemperature Switch

<i>NC Switch</i> opens at 180 Deg. +/- 5 Deg. C		
Current Amps	Voltage	Contact Load
6	120 AC	Resistive Loads
3	120 AC	Inductive Loads
3	240 AC	Resistive Loads
2.5	240 AC	Inductive Loads
8	12 VDC	Resistive Loads
4	24 VDC	Resistive Loads

MTE highly recommends the use of the overtemperature switch to prevent damage to the filter in rare instances of overheating from abnormal operating conditions.

Power Wiring Connection

WARNING	Input and output power wiring to the filter should be performed by authorized personnel in accordance with the NEC and all local electrical codes and regulations. Cable lugs and mounting hardware are provided by the customer.
	Any extremely low or high resistance readings indicate miswiring and may result in damage to filter components if not corrected.

Verify that the rating of the filter is compatible with the drive to which it is to be connected. Follow all detailed drive manufacturer installation and safety instructions. Drive and load cable selection / placement should be in accordance with the requirements of the NEC and all local electrical codes and regulations.

The typical interconnection diagrams that follow are shown for a motor load but the load can be either a motor or a transformer.

- For panel mounted filter applications, interconnection between the filter, its power source, the cap-panels, and the drive is shown in Figure 5-1: Modular Interconnection (p16).
- For isolation transformer connections between the filter, motor and the drive is shown in Figure 5-3: Isolation Transformer (p18).

Wire gauge range and terminal torque requirements as well as selecting conductors that interconnect the reactor and capacitor assemblies are shown in Table 5-2: Torque Ratings (p19).

Refer to the drive user manual for instructions on interconnecting the drive and motor and the correct start-up procedures for the drive.

The filter is designed for use with copper conductors with a minimum temperature rating of 75 degrees C.

Wiring Checks

Using Figure 5-2: Basic Schematic Diagram (p17), visually check the wired components to confirm, verify, and correct wiring. Then, with a multi meter check phase to phase isolation using the 100 K ohm range. The multi meter will read the parallel equivalent of the bleeder resistors after the capacitors initially charge. All phase to phase resistance values should be the same.

Check for the Following Faults:

- Capacitor shorted
- Capacitor bus not connected
- Capacitor bus to chassis short
- Paralleling wiring errors

Modular Unit Interconnection Diagram

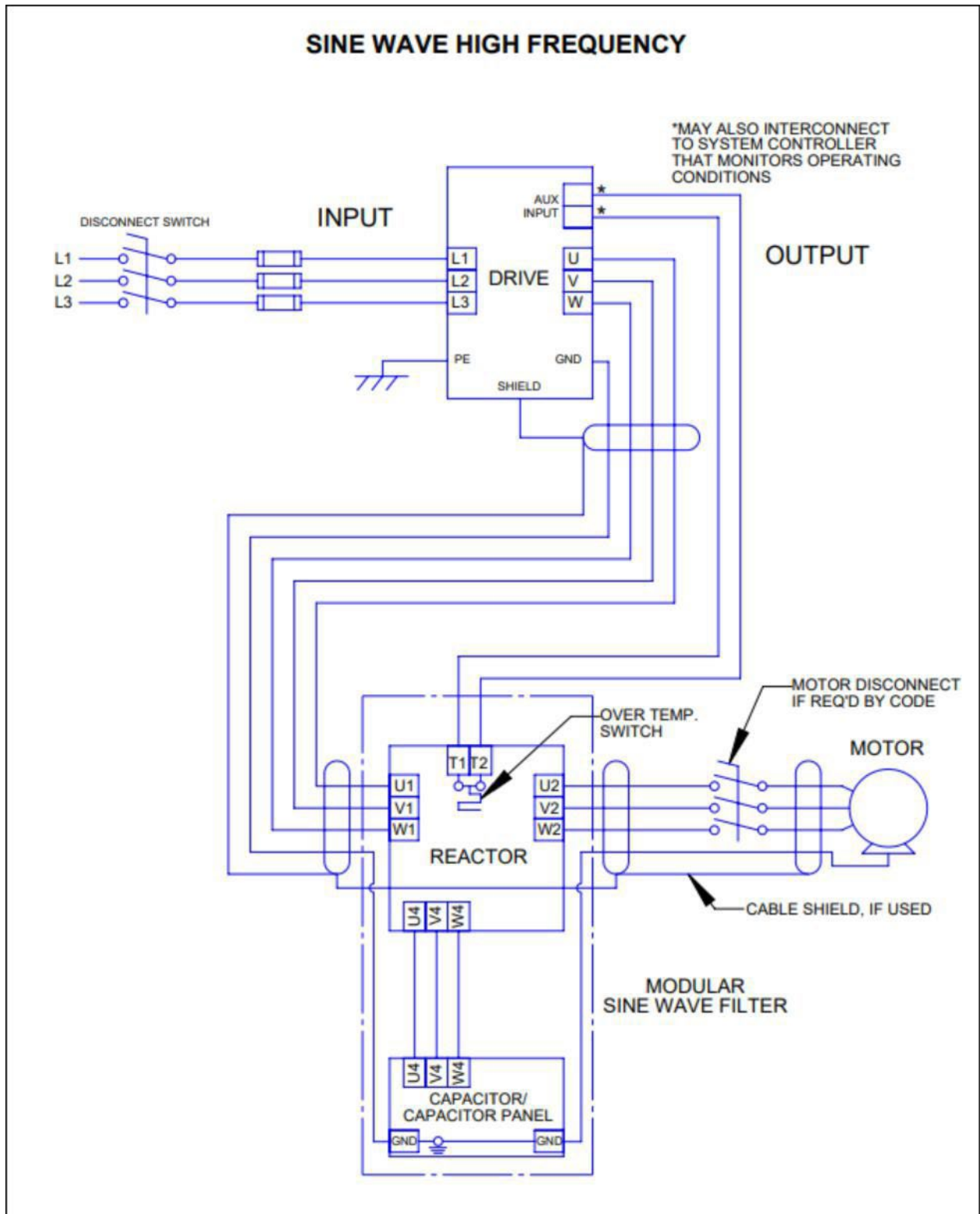

Figure 5-1: Modular Interconnection

Basic Schematic Diagram

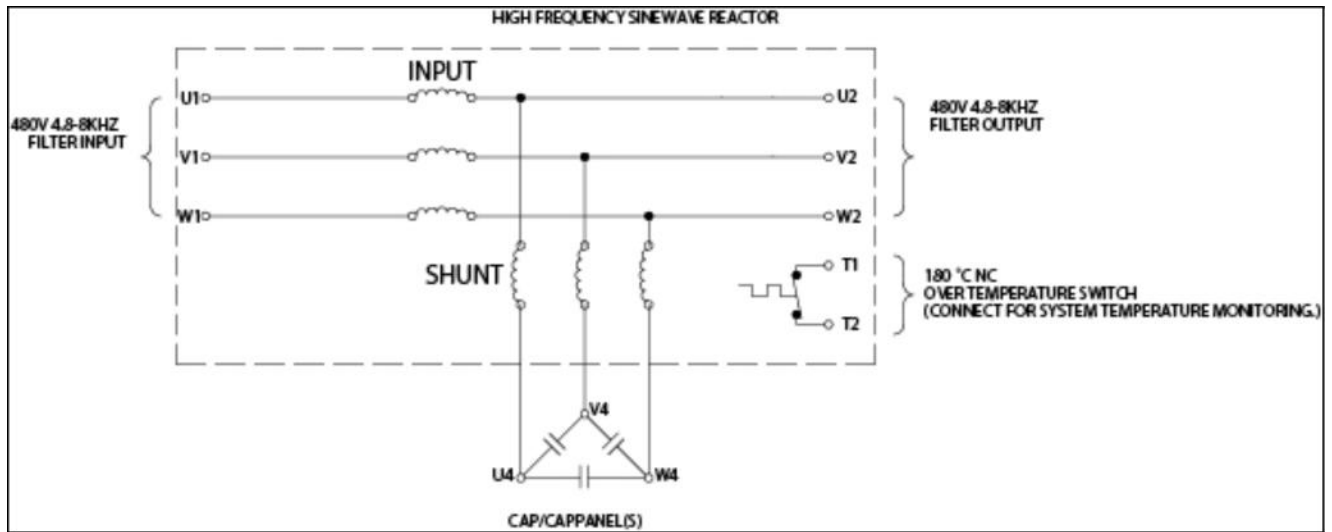

Figure 5-2: Basic Schematic Diagram

Isolation Transformer Diagram

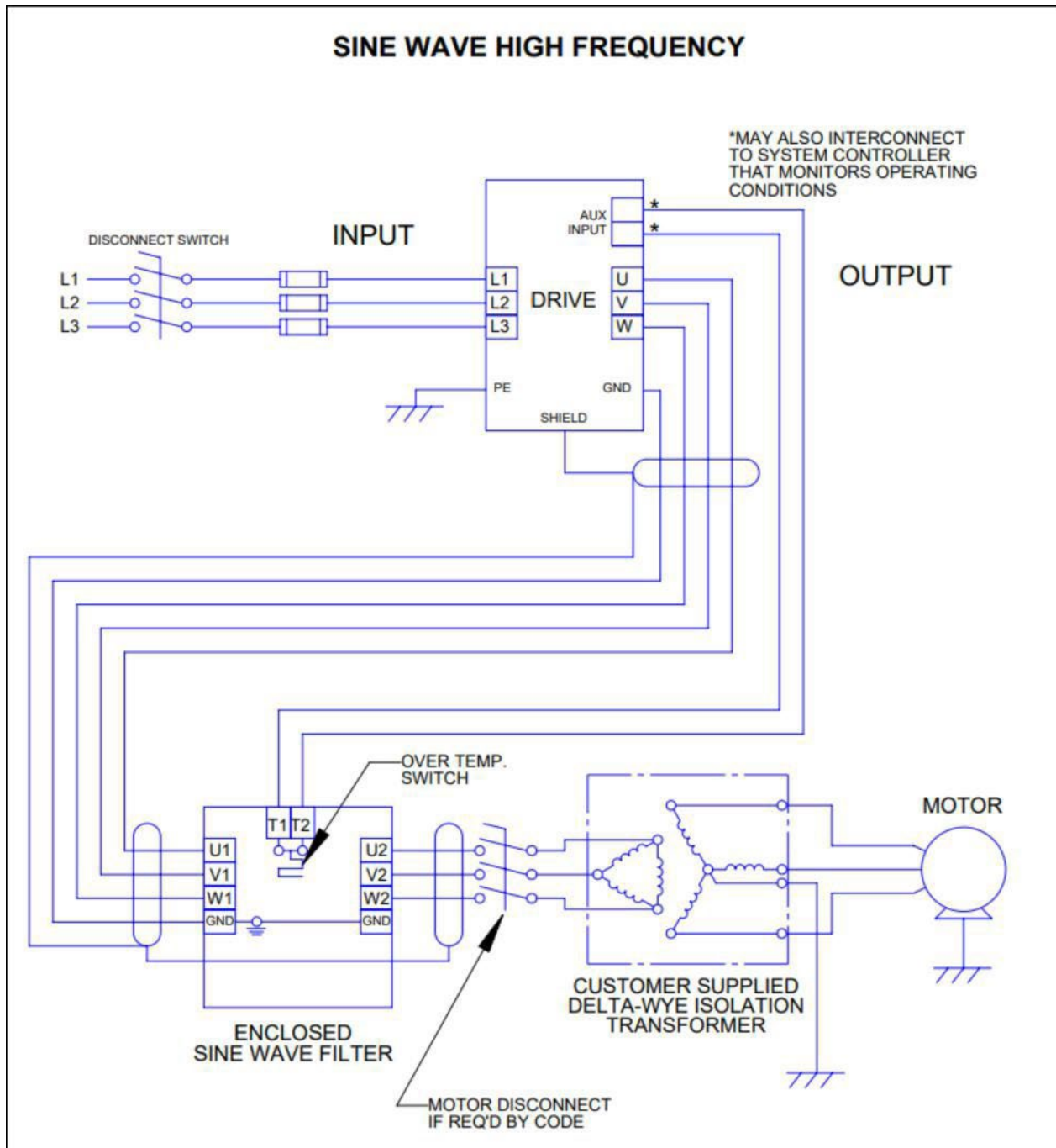

Figure 5-3: Isolation Transformer

Torque Ratings

Table 5-2: Torque Ratings for 2kHz

Filter Rating (Amps)	HF-SWG Terminals			Cap-panel Terminals U4-V4-W4		
	Input /Output Power U1-V1-W1 / U2-V2-W2		U4-V4-W4 interconnect Cap-panel	Capacitor/ Cap-panel Part Number	Minimum Interconnect Wire Gauge (AWG)	Terminal Torque (in-lbs.)
	Recommended Minimum Wire Size (AWG)	Terminal Torque (in-lbs.)	Terminal Torque (in-lbs.)			
200	3 (2x) or 1/0	N/A	N/A	CAPPANEL-606C	8	58
250	1 (2x) or 250K CMIL	N/A	N/A	CAPPANEL-623C	8	58
305	2/0 (2x)	N/A	N/A	CAPPANEL-623C	8	58
415	4/0 (2x)	N/A	N/A	CAPPANEL-611C	4	58
515	300 MCM (2x)	N/A	N/A	CAPPANEL-623C (2x)	8	58
650	500K CMIL (2x)	N/A	N/A	CAPPANEL-137	4	58
			N/A	CAPPANEL-623C (2x)	8	58
1000	600K CMIL(3x)	N/A	N/A	CAPPANEL-610C	8	58
			N/A	CAPPANEL-608C	8	58
1200	800K CMIL(3x)	N/A	N/A	CAPPANEL-610C (2x)	8	58

NOTE: Cap-panel interconnect wiring specification according to UL508 75° C Table.

NOTE: To prevent flexing or bending of the coil windings attached to SWG reactor use appropriate strain relief to prevent stress on terminals. For flat copper terminal tabs, use two wrenches to tighten customer provided cable mounting hardware.

NOTE: Refer to reference drawings for termination wire ranges.

Table 5-3: Torque Ratings for 3.5kHz

Filter Rating (Amps)	HF-SWG Terminals			Cap-panel Terminals U4-V4-W4		
	Input /Output Power U1-V1-W1 / U2-V2-W2		U4-V4-W4 interconnect Cap-panel	Capacitor/ Cap-panel Part Number	Minimum Interconnect Wire Gauge (AWG)	Terminal Torque (in-lbs.)
	Recommended Minimum Wire Size (AWG)	Terminal Torque (in-lbs.)	Terminal Torque (in-lbs.)			
200	3 (2x) or 1/0	N/A	N/A	CAPPANEL-170	4	58
250	1 (2x) or 250K CMIL	N/A	N/A	CAPPANEL-003	4	58
				CAPPANEL-009	4	58
305	2/0 (2x)	N/A	N/A	CAPPANEL-003	4	58
				CAPPANEL-009	4	58
415	4/0 (2x)	N/A	N/A	CAPPANEL-002 (3x)	4	58
515	300 MCM (2x)	N/A	N/A	CAPPANEL-170 (3x)	4	58
650	500K CMIL (2x)	N/A	N/A	CAPPANEL-170 (3x)	4	58

NOTE: Cap-panel interconnect wiring specification according to UL508 75° C Table.

NOTE: To prevent flexing or bending of the coil windings attached to SWG reactor use appropriate strain relief to prevent stress on terminals. For flat copper terminal tabs, use two wrenches to tighten customer provided cable mounting hardware.

NOTE: Refer to reference drawings for termination wire ranges.

Table 5-4: Torque Ratings for 5kHz

Filter Rating (Amps)	HF-SWG Terminals			Cap-panel Terminals U4-V4-W4		
	Input /Output Power U1-V1-W1 / U2-V2-W2		U4-V4-W4 interconnect Cap-panel	Capacitor/ Cap-panel Part Number	Minimum Interconnect Wire Gauge (AWG)	Terminal Torque (in-lbs.)
	Recommended Minimum Wire Size (AWG)	Terminal Torque (in-lbs.)	Terminal Torque (in-lbs.)			
80	4	N/A	N/A	CAPPANEL-006	10	60
110	2	N/A	N/A	CAPPANEL-007	8	60
130	1	N/A	N/A	CAPPANEL-008	8	60
160	4 (2x) or 2/0	N/A	N/A	CAPPANEL-009	6	60
200	3 (2x) or 1/0	N/A	N/A	CAPPANEL-003	4	58
250	1 (2x) or 250K CMIL	N/A	N/A	CAPPANEL-002	4	58
305	2/0 (2x)	N/A	N/A	CAPPANEL-002	4	58
415	4/0 (2x)	N/A	N/A	CAPPANEL-002 (2x)	4	58
515	300 MCM (2x)	N/A	N/A	CAPPANEL-002	4	58
			N/A	CAPPANEL-003 (2x)	4	58
600	400K CMIL (2x)	N/A	N/A	CAPPANEL-002	4	58
			N/A	CAPPANEL-003 (2x)	4	58

NOTE: Cap-panel interconnect wiring specification according to UL508 75° C Table.

NOTE: To prevent flexing or bending of the coil windings attached to SWG reactor use appropriate strain relief to prevent stress on terminals. For flat copper terminal tabs, use two wrenches to tighten customer provided cable mounting hardware.

NOTE: Refer to reference drawings for termination wire ranges.

6. START-UP Safety Precautions

Before start-up, observe the following warnings and instructions:

	<p>Internal components of the filter are at line potential when the filter is connected to the drive. This voltage is extremely dangerous and may cause death or severe injury if you come in contact with it.</p>
<p>WARNING</p>	<p>Remove all power to the SineWave Guardian filter in compliance to standardized 26 CFR 1920.147 lockout/tagout policies. After removing power, allow at least five minutes to elapse and verify that the capacitors have discharged to a safe level before contacting internal components. Connect a DC voltmeter across the capacitor terminals and ensure that the voltage is at a safe level.</p>
	<p>Use extreme caution to avoid contact with line voltage when checking for power. INJURY OR DEATH MAY RESULT IF SAFETY PRECAUTIONS ARE NOT OBSERVED.</p>
<p>Caution</p>	<p>Prior to start-up; confirm the drive operation mode is property set (Volts per Hertz). Please consult drive manual/manufacturer to configure proper parameters. Failure to do so may result in failure of drive or filter components.</p>
	<p>Damage to the filter may occur if the output frequency is not set between 4.8 kHz and 8 kHz. Optimum output frequency is 5 kHz.</p>
	<p>MTE recommends 10 seconds as an initial starting point for motor ramp time and that customers examine the actual inrush and ratings of their drive system. Inrush current seen at the drive from the filter that can easily be overcome by changing the motor ramp time.</p>

Sequence of Operation

1. Read and follow safety precautions.
2. After installation, ensure that:
 - a. All filter ground terminals are connected to ground.
 - b. Power wiring to the utility, drive, filter, capacitor panels and motor is in accordance with the power wiring connection diagrams shown in installation instructions section.
3. Check that moisture has not condensed on the filter components. If moisture is present, do not proceed with start-up until the moisture has been removed.
4. Disconnect filter output terminals from the motor.
5. Set the drive switching frequency between 2 kHz and 8 kHz. Refer to the drive user manual.
6. Connect filter temperature safety overload switch into the control circuit so that the drive will shut down in an overload situation.
7. Confirm that drive voltage is present at the input terminals (U1, V1, W1) of the filter.
8. Confirm that drive voltage is present at the output terminals (U2, V2, W2) of the filter.
9. Connect the filter output to the motor.
10. Refer to the drive user manual for the drive start-up procedure. Observe all safety instructions in the drive user manual.

7. TROUBLESHOOTING

WARNING	<p>When properly installed, this equipment has been designed to provide maximum safety for operating personnel. However, hazardous voltages and elevated temperatures exist within the confines of the enclosure. Servicing should therefore be performed by qualified personnel only and in accordance with OSHA Regulations.</p>
	<p>High voltage is used in the operation of this filter. Use Extreme caution to avoid contact with high voltage when operating, installing or repairing this filter. INJURY OR DEATH MAY RESULT IF SAFETY PRECAUTIONS ARE NOT OBSERVED.</p>
Caution	<p>After removing power, allow at least five minutes to elapse and verify that the capacitors have discharged to a safe level before contacting internal components. Connect a DC voltmeter across the capacitor terminals or terminals U1, V1 or V1, W1 and ensure that the voltage is at a safe level.</p>
	<p>Component may be hot +100°C/212°F</p>

To aid in troubleshooting, a basic schematic diagram, two interconnection diagrams and a troubleshooting guide that lists potential problems and solutions are included:

Figure 5-1: Modular Interconnection (p16)

Figure 5-2: Basic Schematic Diagram (p17)

Figure 5-3: Isolation Transformer (p18)

Table 7-1: Troubleshooting Guidee (p25)

Table 7-1: Troubleshooting Guide

Possible cause:	Motor ramp-up time too short.
Solution:	MTE suggests a ramp time of >5-10 seconds. Consult drive manufacturers manual to configure proper parameters.
Possible cause:	Failed or incorrect wiring
Solution:	Verify all field and product wiring is correct.
Possible cause:	Parameter compatibility.
Solution:	Consult drive manufacturers manual for operating drive with a motor protection filter.
Possible cause:	Filter, Drive, Motor current ratings compatible.
Solution:	Verify the filter and motor are properly sized for the application.
Possible cause:	Drive not configured for Volts/ Hertz
Solution:	Vector control might be required for PM Motors in some applications. Consult drive manufacturers manual to configure proper parameters.
Possible cause:	Motor winding fault.
Solution:	Verify motor windings and hi-pot is necessary.
Possible cause:	Cable failure.
Solution:	Verify cable continuity and insulation.
Possible cause:	Mismatched motor rating.
Solution:	Verify the filter is properly sized for the application.
Possible cause:	Capacitors disconnected or improperly wired.
Solution:	Verify the proper connection of the capacitors.
Possible cause:	Carrier frequency less than 4.8 kHz.
Solution:	Verify the carrier frequency is at least 4.8 kHz.
Possible cause:	Mismatched motor rating.
Solution:	Verify the filter is properly sized for the application.
Possible cause:	Capacitors disconnected or improperly wired.
Solution:	Verify the proper connection of the capacitors.
Possible cause:	Carrier frequency less than 4.8 kHz.
Solution:	Verify the carrier frequency is at least 4.8 kHz.
Possible cause:	Excessive ambient temperature.
Solution:	Ensure filter is operating within specified ambient temperature below 60° C.
Possible cause:	No power.
Solution:	Check fuses or breakers for proper input power.
Possible cause:	Motor incorrectly wired.
Solution:	Check for wiring faults.
Possible cause:	Locked rotor motor load.
Solution:	Check motor load.
Possible cause:	Drive fault.
Solution:	Consult drive manufacturers manual.
Possible cause:	Capacitors disconnected or improperly wired.
Solution:	Verify the proper connection of the capacitors.
Possible cause:	Overloaded motor.
Solution:	Verify the motor is properly sized for the application.

High Frequency SineWave Guardian 380V – 480V Technical Reference Manual			SHF-TRM-E
Responsibility: VP Business Development and Product Management Approved By: Z Zakaria ISO Section: 7.2.3			
Revision	Date	Revision History	Changed By
001	04/01/15	New document written	Stu Accola
002	09/26/17	Removed Appendix; Updated to new format	Chase Young
003	05/8/19	Updated logo; added “*” note to Table 3.1 on Pg. 5; added quantities of CAPPANELs to selection table and torque ratings table	Marc Majewski
004	01/11/23	Added models for 2kHz and 35kHz frequencies, including relevant product information.	John Gregor
005	01/31/25	Added 1000A & 1200A torque ratings for 2kHz Updated Part #'s for Modular Selection Tables for 2kHz & 3.5kHz	Drew Nackel

