



POWER QUALITY. SOLVED.
A STEEL PARTNERS COMPANY

Matrix[®] AP+

480V

TECHNICAL REFERENCE MANUAL



High Voltage! Only a qualified electrician can carry out the electrical installation of this filter.

Quick Reference

1	Performance Data	Pages 5 - 8
2	Selection Guide	Pages 10 - 11
3	Installation Guide	Pages 12 - 20
4	Start-up/Troubleshooting	Pages 21 - 25

This page intentionally left blank

TABLE OF CONTENTS

1. SAFETY	1
WARNINGS AND CAUTIONS	1
GENERAL SAFETY INSTRUCTIONS	2
2. GENERAL INFORMATION	3
RECEIPT & REPAIR STATEMENT	3
ENCLOSURES	4
WARRANTY	4
3. MATRIX AP+ PERFORMANCE DATA	5
PERFORMANCE SPECIFICATIONS	5
ALTITUDE DERATING	8
TEMPERATURE DERATING	8
4. HOW TO SELECT	10
SELECTION GUIDE	10
UNDERSTANDING THE MATRIX AP+ PART NUMBER:	11
5. HOW TO INSTALL	12
INSTALLATION CHECKLIST	12
GROUNDING	12
POWER WIRING CONNECTION	13
BASIC SCHEMATIC DIAGRAM	15
ENCLOSED UNIT INTERCONNECTION DIAGRAM	16
CONTACTOR OPTION	17
CONTACTOR COIL SWITCHING CURRENTS	19
TORQUE RATINGS MATRIX AP+ 480V	20
6. START-UP	21
SAFETY PRECAUTIONS	21
7. TROUBLESHOOTING	23
MATRIX AP+ HARMONIC FILTER FIELD CHECKS	24

List of Figures

Figure 3-1: Load Effect on THID @ 15% THVD	7
Figure 3-2: Power Factor	7
Figure 3-3: Altitude Derating Curve	8
Figure 3-4: Temperature Derating	8
Figure 3-5: Voltage Distortion Derating Curve	9
Figure 5-1: Basic Schematic Diagram	15
Figure 5-2: Enclosed Interconnection	16
Figure 5-3: Contactor Option – 002	17
Figure 5-4: Contactor Option – 009	18



List of Tables

Table 3-1: Performance Specifications	5
Table 3-2: Watt Loss – Matrix AP+ 480V, 60 Hz	6
Table 5-1: Overtemperature Switch	13
Table 5-2: Contactor Coil Switching Currents	19
Table 5-3: Torque Ratings – 480V	20
Table 7-1: Troubleshooting Guide	25



1. SAFETY

Warnings and Cautions

The following symbols are used in this manual:

 WARNING	High Voltage Warning: warns of situations that dangerously high voltage is involved. Failure to use proper precautions may lead to serious injury or death.
 WARNING	General Warning: warns of situations that can result in serious injury or death if proper precautions are not used.
 Caution	General Caution: identifies situations that could lead to malfunction or possible equipment damage.

General Safety Instructions

 WARNING	<p>High Voltage! Only a qualified electrician can carry out the electrical installation of this filter.</p>
	<p>High voltage is used in the operation of this filter. Use extreme caution to avoid contact with high voltage when operating, installing or repairing this filter. Injury or death may result if safety precautions are not observed.</p>
 WARNING	<p>The opening of the branch circuit protective device may be an indication that a fault current has been interrupted. To reduce the risk of fire or electrical shock, current-carrying parts and other components of the filter should be examined and replaced if damaged.</p>
	<p>An upstream disconnect/protection device must be used as required by the National Electrical Code (NEC) or governing authority.</p>
	<p>Even if the upstream disconnect/protection device is open, the drive downstream of the filter may feedback high voltage to the filter. The drive safety instructions must be followed. Injury or death may result if safety precautions are not observed.</p>
	<p>The filter must be grounded with a grounding conductor connected to all grounding terminals. Open panel filters must have reactor grounded through a 2"x2" area cleaned of paint and varnish on lower mounting bracket.</p>
	<p>Only spare parts obtained from MTE Corporation or an authorized MTE distributor can be used.</p>
	<p>After removing power, allow at least five minutes to elapse and verify that the capacitors have discharged to a safe level before contacting internal components. Connect a DC voltmeter across the capacitor terminals and ensure that the voltage is at a safe level.</p>
 Caution	<p>Loose or improperly secured connections may damage or degrade filter performance. Visually inspect and secure all electrical connections before power is applied to the filter.</p>
	<p>The user of this filter must assure that the input voltage and frequency is correct for the filter rating and that the voltage applied falls within the rated operating tolerance envelop specified for the filter. For sever power line applications where the power feed is likely to experience surges and transients that exceed the input voltage rating, it is recommended that a TVSS (Transient Voltage Surge Suppression) or SPD (Surge Protection Device) be deployed ahead of the filter to reduce the possibility of exceeding the filter rated voltage. Consult with TVSS or SPD manufacturer to determine the correct protection requirements for your power line conditions.</p>

2. GENERAL INFORMATION

The purpose of the manual is to properly specify, size, and install the Matrix AP+.

For the most current Matrix AP+ information, please refer to our website:

www.mtecorp.com/products/matrix_ap_plus/



Scan this QR Code!

This manual is intended for use by personnel experienced in the operation and maintenance of drives. Because of the high voltages required by the filter, drive and the potential dangers presented by rotating machinery, it is essential that all personnel involved in the operation and maintenance of this filter know and practice the necessary safety precautions for this type of equipment. Personnel should read and understand the instructions contained in this manual before installing, operating or servicing the filter and drive to which it is connected.

Receipt & Repair Statement

Upon Receipt of this Filter:

The Matrix AP+ harmonic filter has been subjected to demanding factory tests before shipment. Carefully inspect the shipping container for damage that may have occurred in transit. Then unpack the filter and carefully inspect for any signs of damage. Save the shipping container for future transport of the filter.

In the event of damage, please contact and file a claim with the freight carrier involved immediately.

If the equipment is not going to be put into service upon receipt, cover and store the filter in a clean, dry location. After storage, ensure that the equipment is dry and that no condensation or dirt has accumulated on the internal components of the filter before applying power.

Repair/Exchange Procedure

MTE Corporation requires a Return Material Authorization Number and form before we can accept any filters that qualify for return or repair. If problems or questions arise during installation, setup, or operation of the filter, please contact MTE for assistance at:

Toll Free: 1-800-455-4MTE (1-800-455-4683)
International Tel: (+1)-262-253-8200
Fax: (+1)-262-253-8222

Enclosures

MTE enclosures are designed to provide a degree of protection for electrical components and prevent incidental personnel contact with the enclosed equipment. Depending on the enclosure selected, these enclosures meet the requirements of NEMA 1, 2 or 3R.

An approximate cross reference guide between NEMA, UL, CSA and IEC enclosure follows.

Type 3R NEMA / IEC IP23 Enclosure:

Are designed for outdoor use primarily to provide protection against contact with the enclosed equipment and provide a degree of protection against falling rain sleet and external ice formation.

Agency Approvals

UL and cUL listed to UL508 Type Mx and CSA-C22.2 No 14-95
File E180243

Warranty

Three years from the date of shipment. See <https://www.mtecorp.com/industry-leading-warranty/> for details.



Scan this QR Code!

3. MATRIX AP+ PERFORMANCE DATA

Performance Specifications

Table 3-1: Performance Specifications

Service Conditions	Load: 6-pulse variable torque rectifier only
Input Voltage(s)	480V Version - 480 VAC +/- 10%, 60 + 0.75 Hz. 3 phase
Input voltage line unbalance	1% maximum to ensure performance guaranty
Maximum source impedance	6.00% to ensure performance guaranty. Please contact MTE for sizing with Gensets.
Minimum source impedance	1.5%
Service Factor	1.00
Overload	150% for 1-minute duration with 10% output voltage reduction of nominal of voltage
Ambient Temperature (Operating)	Refer to Figure 3-4: Temperature Derating for derating guidelines
Insulation System	Class N (200 degrees C)
Enclosed Filters	-40-55 degrees C with no derating
Open Panel Filters	-40 to +55 degrees C with no derating
Storage Temperature	-40 to +90 degrees C
Altitude	0 to 3300 Feet above sea level. Refer to Figure 3-3: Altitude Derating Curve for altitude de-rating
Relative Humidity	0 to 95% non-condensing
Over Voltage	Category II
Insertion Loss	+5% no load -5% full load
Maximum THID	15-25% at full load
THVD Conditions	Fully functional up to 15% THVD environment, protective measures above 15% THVD

Generator sizing note: Generator sizing is best completed by sizing programs or help from a generator manufacturing representative. Identify every load type and size that will be powered from the generator. If non-linear loads are present, the generator may need to be oversized.
 Generator rated KVA minimum load \geq Matrix rated current $\times \sqrt{3}$ generator voltage
 FLA load current \leq Matrix filter rated current

Notes (SCCR):

MTE products are manufactured and certified to the UL 508 standard.

Regarding the UL 508A standard (for industrial control panels, third edition, dated April 24, 2018, and current), the default short circuit current rating (SCCR) for the harmonic filter used within the industrial control panel is defined in Table SB4.1.

The default short circuit rating can be increased by appropriately fusing the shunt section within the harmonic filter, or, appropriately fusing each capacitor branch within the shunt section of the harmonic filter, per UL508A Table SB4.2. By adding this protective fusing, the harmonic filter SCCR rating can be increased to 100kA. Contact MTE for the applicable application note.

Filter Efficiency + Watt loss Matrix AP+ 480V, 60Hz

Table 3-2: Watt Loss - Matrix AP 480V, 60Hz

Maximum Output (Amps RMS)	Efficiency (%)	Typical Power Dissipation @ Rated Current (Watts)	Typical Capacitor Current (Amps RMS)
208	99.2%	1437	93.6
320	99.4%	1505	144
403	99.4%	2192	181.4
482	99.5%	2167	216.9
636	99.5%	3005	286.2
786	99.6%	3618	353.7
1000	99.5%	4318	450

NOTE: Use the IEC AC-3 rating for the corresponding filter capacitor current when selecting a contactor.

Figure 3-1: Load Effect on THID @ 15% THVD

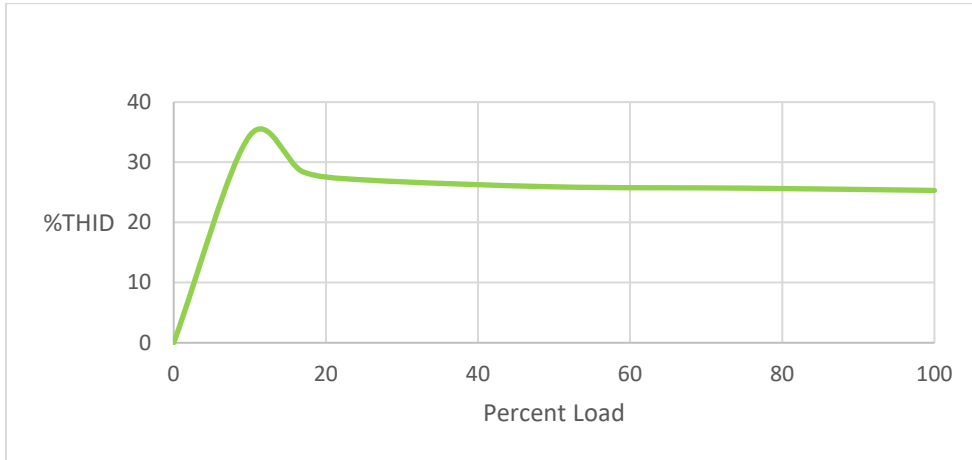

Power Factor

Figure 3-2: Power Factor

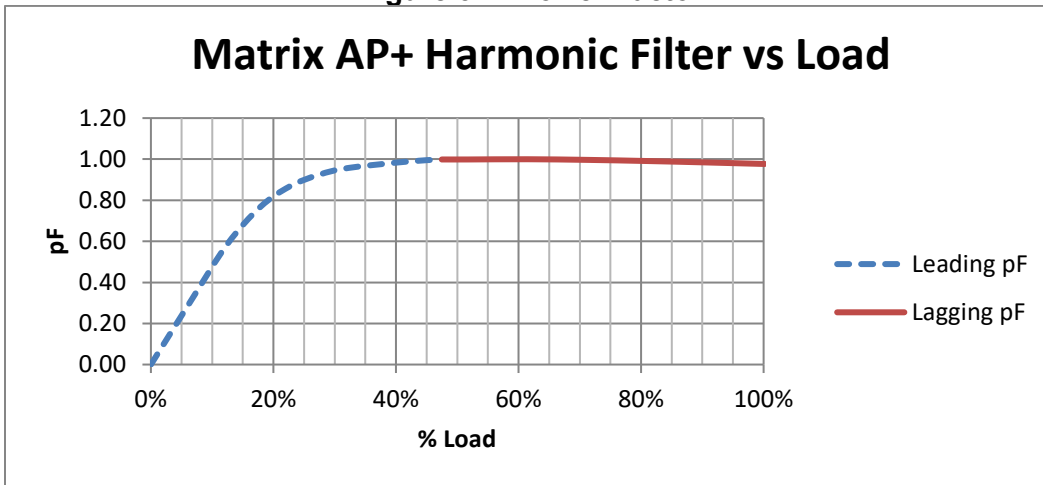

Altitude Derating

Figure 3-3: Altitude Derating Curve

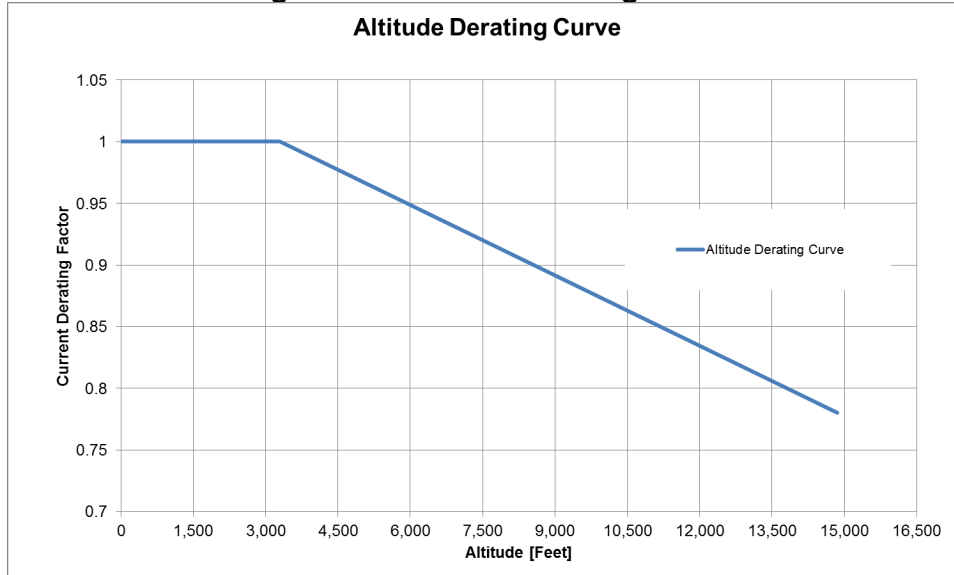

Temperature Derating

Figure 3-4: Temperature Derating

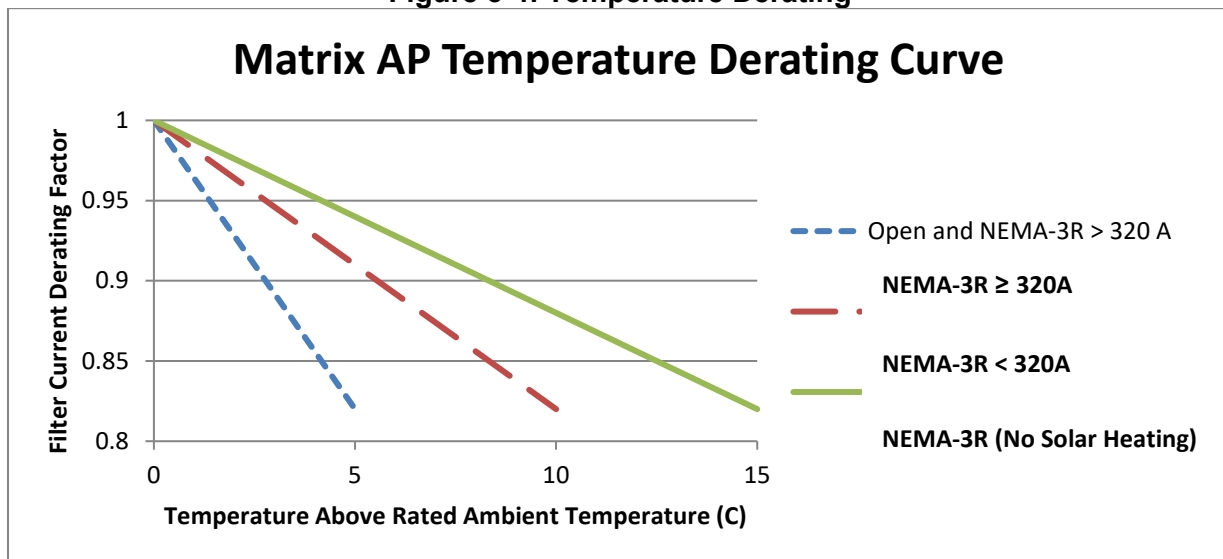

NOTE: No need to derate before 55C. Do not extend derating beyond published data. See or click Table 3-1: Performance Specifications (p5) for temperature ratings

THVD Derating

Figure 3-5: Voltage Distortion Derating Curve

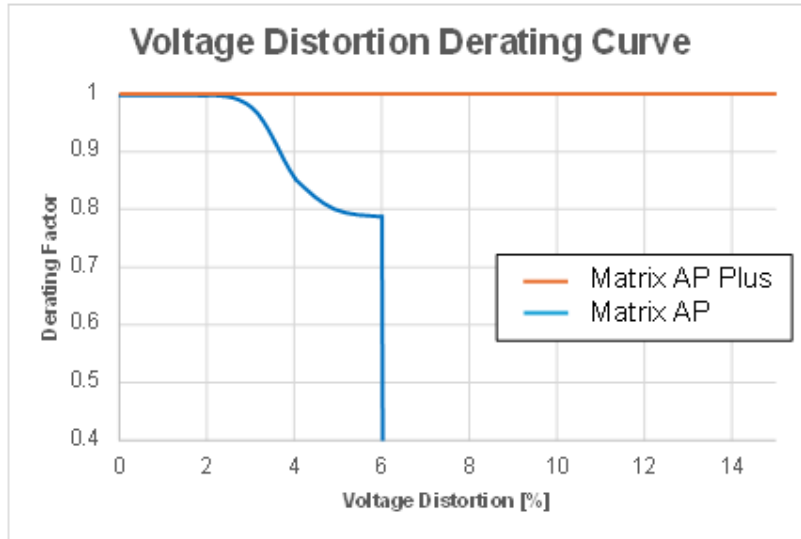

Note: This plot assists in proper derating of the Matrix AP Plus in environments with a given voltage distortion. Example: In a system with 15% voltage distortion, a Matrix AP+ filter does not need to be oversized to function vs an appropriate filter in a 0% distortion environment.

4. HOW TO SELECT

Selection Guide

The MTE Corporation Matrix AP+ harmonic filter is designed for harmonic mitigation of 6-pulse inverter drives supplying variable torque loads in a wide variety of applications. The suitability of this filter for a specific application must therefore be determined by the customer. In no event will MTE Corporation assume responsibility or liability for any direct or consequential damage resulting from the use or application of this filter, nor will MTE Corporation assume patent liability with respect to the use of information, circuits or equipment described in this instruction manual.

Matrix AP+ harmonic filters are available in NEMA 1/2, and NEMA 3R mechanical configurations.

NOTE: For inverters feeding isolation transformers select a filter with a current rating equal to or greater than that of the transformer primary current.

Please verify information below for proper selection:

- Line Voltage and Frequency:** Input voltage from 240V – 1000V at standard frequency. See [Table 3-1: Performance Specifications \(p5\)](#) for specification
- Current Rating:** 480V 208-1000 Amp
- Contactor Option:** See [Figure 5-3: Contactor Option – 002 \(p17\)](#) for contactor option
[Figure 5-4: Contactor Option – 009 \(p18\)](#)
- Performance:** See [Table 3-1: Performance Specifications \(p5\)](#)
- Temperature:** See [Table 3-1: Performance Specifications \(p5\)](#) for specification, and [Figure 3-4: Temperature Derating \(p8\)](#)
- Altitude:** 3,300 feet above sea level without derating. See [Figure 3-3 Altitude Derating Curve \(p8\)](#) for derating curve.
- Enclosure Type:** **NEMA ½ & NEMA 3R, see (p4)** for enclosure descriptions.

Refer to Article 430 Table 430.91 of the National Electrical code for the selection of the appropriate enclosure Type Number for your application.

See website for available models: https://mtecorp.com/matrix_ap_plus/#part-numbers

Understanding the MATRIX AP+ Part Number:

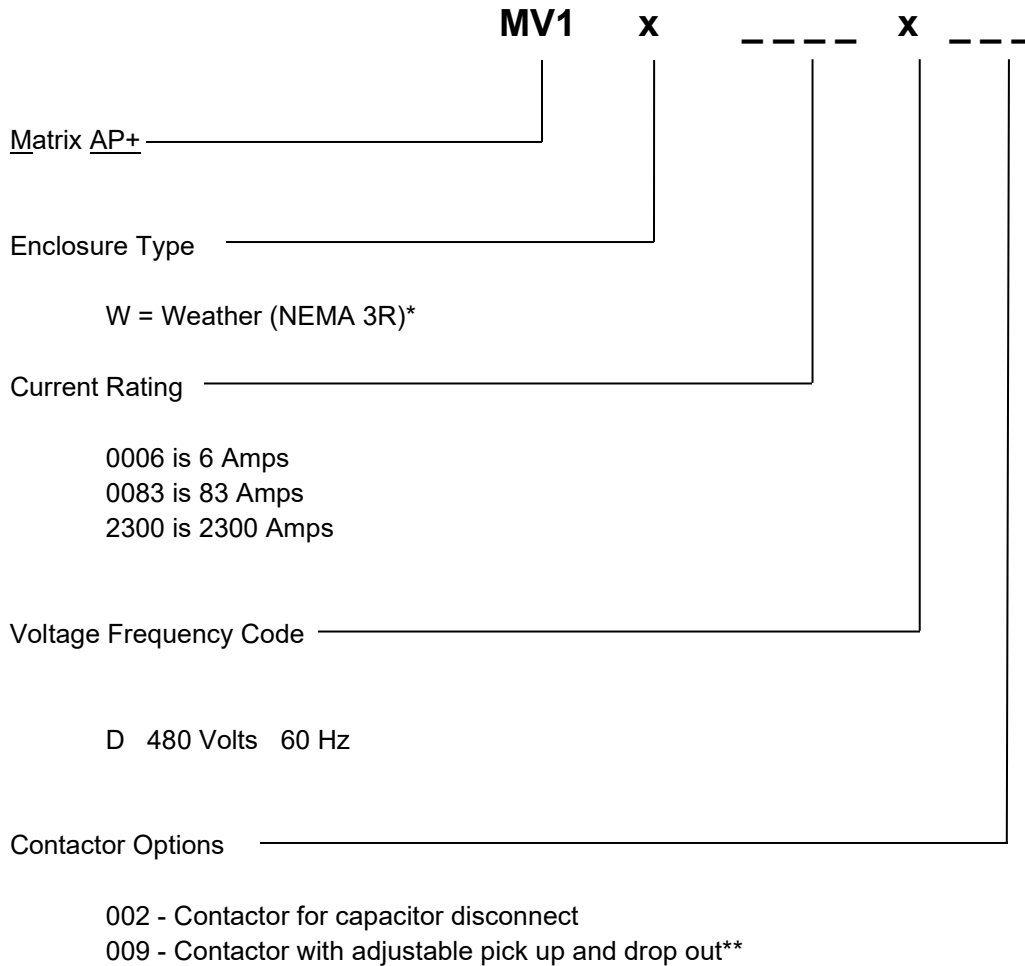

*Note: Any contactor used in the system will serve the following functions:

1. Protecting the capacitors from high THVD
2. Bringing the capacitors in/out of the system



See website for available models: https://mtecorp.com/matrix_ap_plus/#part-numbers



Scan this QR Code!

5. HOW TO INSTALL

Installation Checklist

 WARNING	Prior to installation, please refer to all general warnings on pages 1 & 2. Failure to practice this can result in body injury!
	Input and output wiring to the filter should be performed by authorized personnel in accordance with NEC and all local electrical codes and regulations.
 WARNING	The filter is designed for use with copper conductors with a minimum temperature rating of 75 degrees C.
	Do not install capacitor assembly above/near the Harmonic Mitigating Reactor. Premature or catastrophic failure may occur.

Matrix AP+ filters are supplied in the following mechanical configurations:

- Floor mounted general purpose NEMA 1/2, & NEMA 3R cabinets: Reactor and capacitor/capacitor assemblies are supplied in a cabinet with all items pre-wired together.

Minimum Required Space:

NEMA 3R enclosed filters are designed for floor mounting in an environment suitable for the enclosure type. Do not install in or near a corrosive environment. Allow a minimum side and back clearance of eight (8) inches and front clearance of thirty-six (36) inches for proper heat dissipation and access. For lower ambient temperatures and increased air flow clearance distances can be reduced.

Grounding

 WARNING	The filter must always be grounded with a grounding conductor connected to ground terminals.
	For open panel units, ensure a 2" x 2" area is cleaned of paint and varnish on lower mounting bracket for ground connection.

NOTE: For cable shield grounding follow the drive manufacturer’s recommendations.

Grounding and Ground Fault Protection

The filter must always be grounded with a grounding conductor connected to all ground terminals.

Due to high leakage currents associated with variable frequency drives, ground fault protective devices do not necessarily operate correctly when placed ahead of a Matrix Filter feeding a drive. When using this type of device, its function should be tested in the actual installation.

Overtemperature Interlock

An overtemperature interlock circuit should be used in conjunction with thermal switch to turn off the drive to prevent filter damage due to abnormal operating conditions. The temperature switch is normally closed and will open when an internal reactor temperature of 180°C is reached. See Table 5-1: Overtemperature Switch below for contact rating information and the drive user manual for interconnection information.

Table 5-1: Overtemperature Switch

<i>NC Switch</i> opens at 180 Deg. +/- 5 Deg. C		
Current Amps	Voltage	Contact Load
6	120 AC	Resistive Loads
3	120 AC	Inductive Loads
3	240 AC	Resistive Loads
2.5	240 AC	Inductive Loads
8	12 VDC	Resistive Loads
4	24 VDC	Resistive Loads

MTE highly recommends the use of the overtemperature switch to prevent damage to the filter in rare instances of overheating from abnormal operating conditions.

Power Wiring Connection

 WARNING	<p>Input and output power wiring to the filter should be performed by authorized personnel in accordance with the NEC and all local electrical codes and regulations. Cable lugs and mounting hardware are provided by the customer.</p>
	<p>Any extremely low or high resistance readings indicate a mis-wire and may result in damage to filter components if not corrected.</p>
	<p>On NEMA 3R enclosures, CAB-26AP and larger, no live parts shall be mounted below 8 inches from the bottom of the enclosure.</p>

Verify that the power source to which the filter is to be connected is in agreement with the nameplate data on the filter. A fused disconnect switch or circuit breaker should be installed between the filter and

its source of power in accordance with the requirements of the NEC and all local electrical codes and regulations. Refer to the drive user manual for selection of the correct fuse rating and class.

- For filters supplied in general purpose NEMA 1/2 & NEMA 3R cabinets, interconnection between the filter, its power source, and the drive is shown in **Figure 5-2: Enclosed Interconnection (p15)**.

Wire gauge range and terminal torque requirements as well as selecting conductors that interconnect the HMR and capacitor assemblies are shown in:

- **Table 5-3: Torque Rating – 480V (p20)**.

Filters that use multiple cap-panels share total cap current are shown in:

- **Table 3-2: Watt Loss – Matrix AP+ 480V, 60Hz (p6)**.

Refer to the drive user manual for instructions on interconnecting the drive and motor and the correct start-up procedures for the drive.

The filter is designed for use with copper conductors with a minimum temperature rating of 75 degrees C.

Wiring Checks

Using **Figure 5-1: Basic Schematic Diagram (p15)** and **Figure 5-2: Enclosed Interconnection (p16)**. Visually check the wired components to confirm, verify, and correct wiring. Then, with a multi meter, check phase to phase isolation using the 100 K ohm range. The multi meter will read the parallel equivalent of the bleeder resistors after the capacitors initially charge. All phase-to-phase resistance values should be the same.

Check for the Following Faults:

- Capacitor shorted
- Capacitor bus not connected
- Capacitor bus to chassis short
- Paralleling wiring errors

Basic Schematic Diagram

Figure 5-1: Basic Schematic Diagram

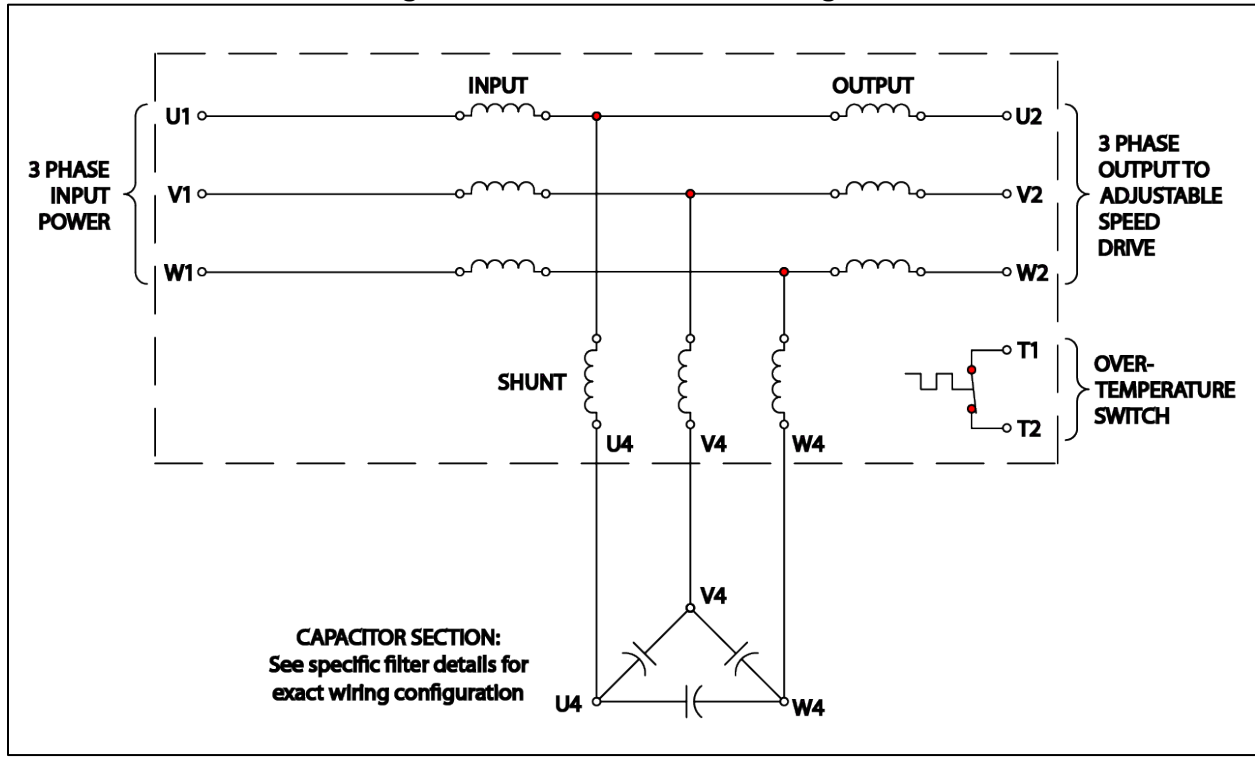

NOTE: Drawing depicts delta configuration for capacitors.

Enclosed Unit Interconnection Diagram

Figure 5-2: Enclosed Interconnection

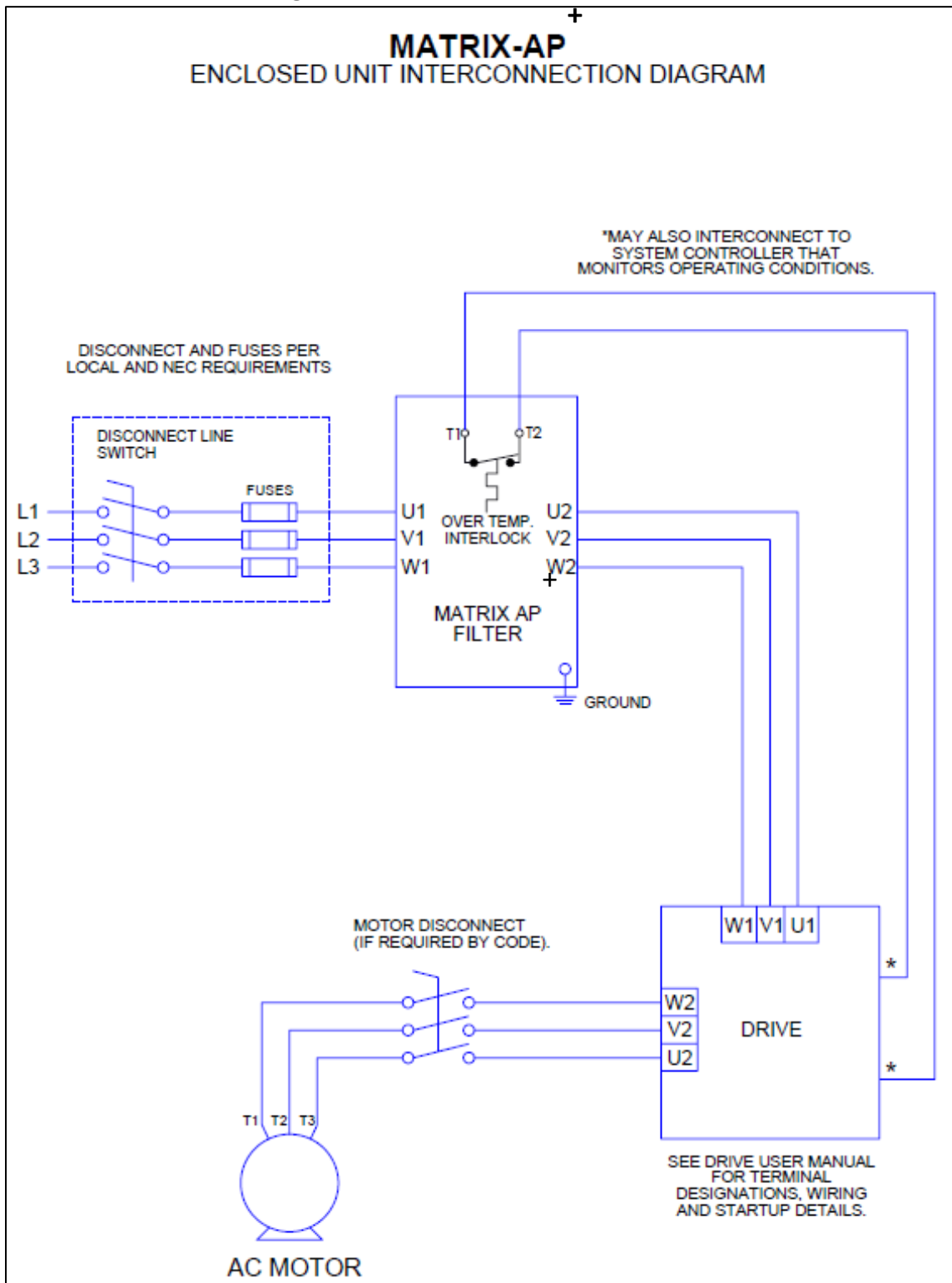

Contactor Option

Option – 002

Capacitor contactor

This option provides a contactor to disconnect the filter capacitor bank when the drive is not running. The contactor is supplied with NO/NC auxiliary contacts. The contactor coil and auxiliary contacts are wired to a customer terminal block. This option is provided pre-wired complete for enclosed filters and as loose parts for open panel filters.

Figure 5-3: Contactor Option – 002

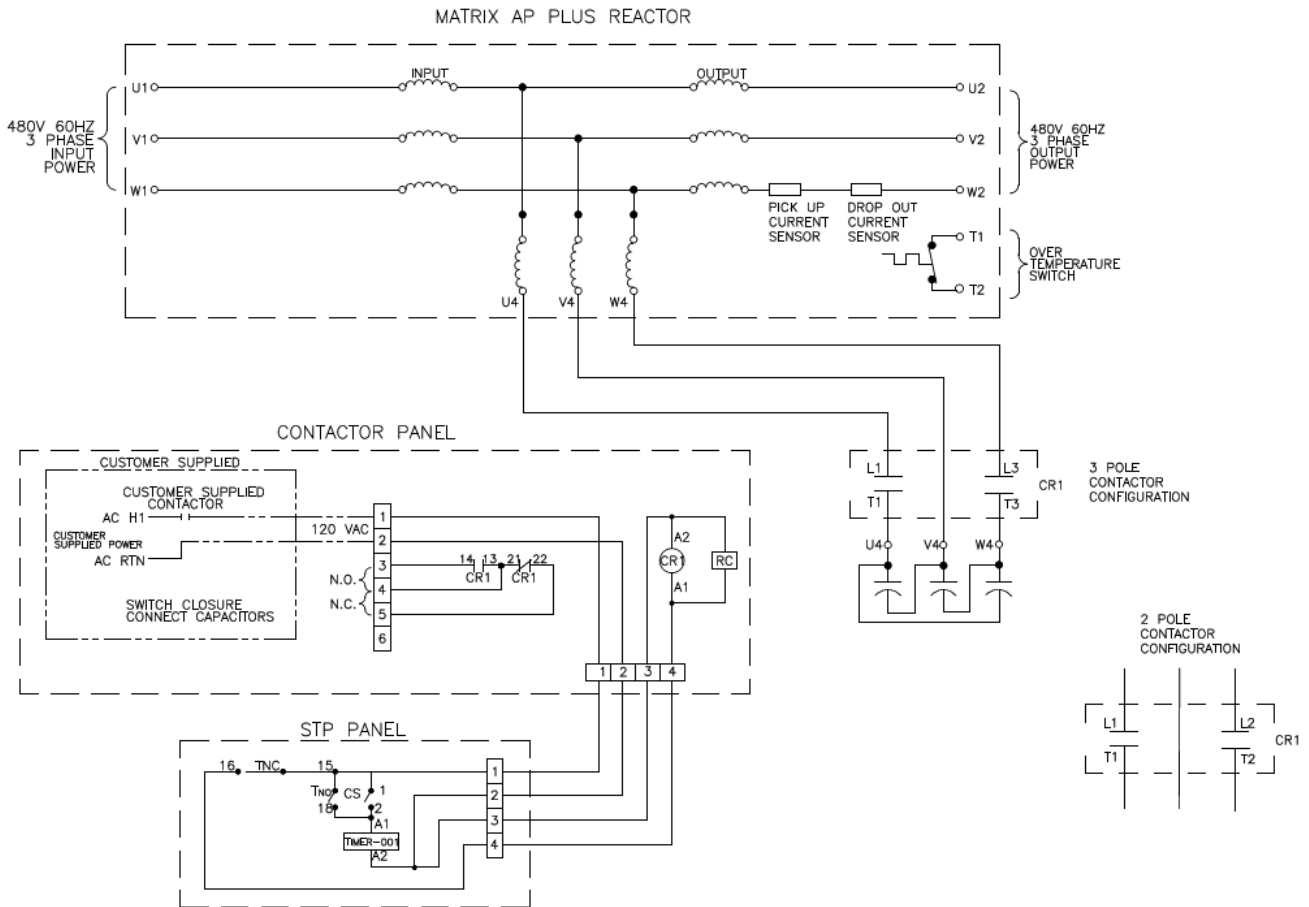

NOTE: The above contactor option diagram is provided to help understand the circuit function and does not reflect actual circuit wiring.

Option – 009

Capacitor contactor with adjustable pick up and drop out

This option provides a contactor to disconnect the filter capacitor bank based on the motor load current. Two current operated switches provide independent adjustment of the pick-up and drop current levels. The switches are preset at the factory for pick up at 35% and drop out at 20% of the filter output current rating. This option is only available for enclosed filters.

Figure 5-4: Contactor Option – 009

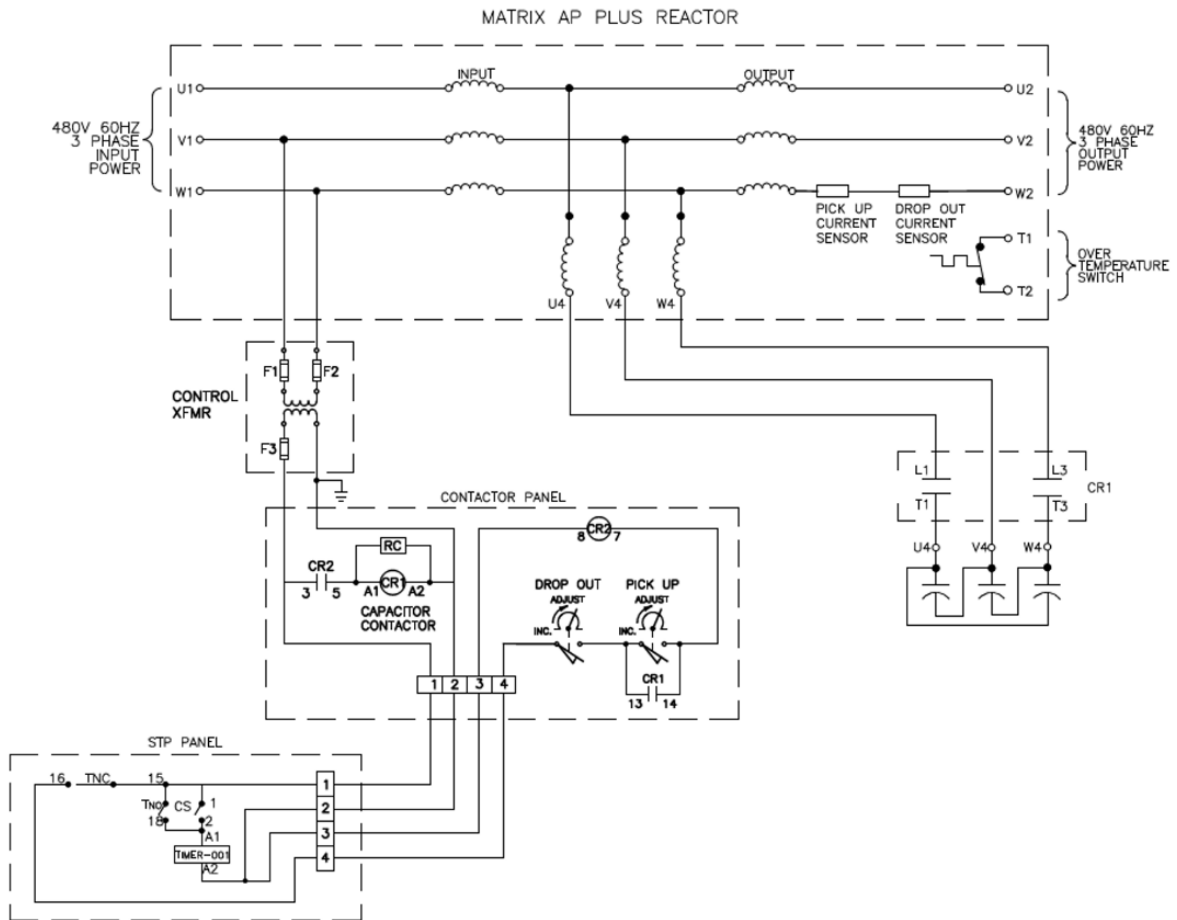

NOTE: The above contactor option diagram is provided to help understand the circuit function and does not reflect actual circuit wiring.

Contactor Coil Switching Currents

Option – 002

The following table indicates the 120 VAC 50/60 Hz current required to switch and hold the various size contactors used in Matrix Filter capacitor switching and bypass options. This data is provided to select the proper switch rating to remotely control the contactor and is consistent for 480V unit.

Contactor Currents for 120 VAC 60 Hz coils.

Table 5-2: Contactor Coil Switching Currents

Matrix filter current Rating AMPS	Capacitor Contactor Option 002 AMPS	
	<i>INRUSH</i>	<i>SEALED</i>
208	1.70	0.304
320	1.41	0.025
403	1.41	0.025
482	2.08	0.036
636	2.08	0.036
786	3.75	0.036
850	3.75	0.036
1000	3.75	0.036

Torque Ratings Matrix AP+ 480V

Table 5-3: Torque Ratings – 480V

Filter Rating (Amps)	Matrix AP HMR Terminals			Cap-panel Terminals U4-V4-W4		
	Input /Output Power U1-V1-W1 / U2-V2-W2		U4-V4-W4 interconnect Cap-panel	480V Capacitor/ Cap-panel Part Number	Minimum Interconnect Wire Gauge (AWG)	Terminal Torque (in-lbs.)
	Wire Range (AWG)	Terminal Torque (in-lbs.)	Terminal Torque (in-lbs.)			
208	Flat copper tab	N/A	16	CAPPANEL-312	1	60
320	Flat copper tab	N/A	16	CAPPANEL-312 CAPPANEL-615C	3	60
403	Flat copper tab	N/A	16	CAPPANEL-312 CAPPANEL-623C	2	60
482	Flat copper tab	N/A	16	(2) CAPPANEL-312	1/0	60
636	Flat copper tab	N/A	16	(2) CAPPANEL-312 CAPPANEL-623C	1	60
786	Flat copper tab	N/A	16	(2) CAPPANEL-312 CAPPANEL-578C	1/0	60
1000	Flat copper tab	N/A	16	(3) CAPPANEL-312 CAPPANEL-578C	1/0	60

6. START-UP

Safety Precautions



Before start-up, observe the following warnings and instructions:

 WARNING	<p>Internal components of the filter are at line potential when the filter is connected to the drive. This voltage is extremely dangerous and may cause death or severe injury if you come in contact with it.</p>
	<p>Remove all power to the Matrix AP filter in compliance to standardized 26 CFR 1920.147 lockout/tagout policies. After disconnecting the utility power, wait at least 5 minutes before doing any work on the filter connections. After removing power, allow at least five minutes to elapse and verify that the capacitors have discharged to a safe level before contacting internal components. Connect a DC voltmeter across the capacitor terminals and ensure that the voltage is at a safe level.</p>
	<p>Use extreme caution to avoid contact with line voltage when checking for power. INJURY OR DEATH MAY RESULT IF SAFETY PRECAUTIONS ARE NOT OBSERVED.</p>
	<p>After disconnecting the utility power, wait at least 5 minutes before doing any work on the filter connections. After removing power, allow at least five minutes to elapse and verify that the capacitors have discharged to a safe level before contacting internal components. Connect a DC voltmeter across the capacitor terminals. Start with the meter on the highest scale and progressively switch to a lower scale as the indicated voltage falls below the maximum value of the scale used.</p>

Sequence of Operation

1. Read and follow safety precautions.
2. After installation, ensure that:
 - All filter ground terminals are connected to ground.
 - Power wiring to the utility, drive and motor is in accordance with the power wiring connection diagrams shown in installation instructions section.
 - Use the following guidelines for power and cap-panel wire gauges:
 - **Table 5-3: Torque Rating – 480V (p20)**
3. Check that moisture has not condensed on the filter components. If moisture is present, do not proceed with start-up until the moisture has been removed.
4. Disconnect the filter output from the drive.
5. Connect the filter to the utility.
6. Confirm that line voltage is present at the input terminals (U, V1, W1) of the filter.
7. Confirm that line voltage is present at the output terminals (U2, V2, W2) of the filter and that it is less than or equal to 1.05 times the input voltage.
8. Using a clamp on Amp meter, check input phase currents to verify they are within a 5% match to each other and approximately 30% of filter current rating.
9. Remove power and verify that **NO VOLTAGE** is present on the filter terminals.
10. Connect the filter output to the drive.
11. Refer to the drive user manual for the drive start-up procedure. Observe all safety instructions in the drive user manual.

7. TROUBLESHOOTING

 WARNING	<p>When properly installed, this equipment has been designed to provide maximum safety for operating personnel. However, hazardous voltages and elevated temperatures exist within the confines of the enclosure. Servicing should therefore be performed by qualified personnel only and in accordance with OSHA Regulations.</p>
	<p>High voltage is used in the operation of this filter. Use Extreme caution to avoid contact with high voltage when operating, installing or repairing this filter. INJURY OR DEATH MAY RESULT IF SAFETY PRECAUTIONS ARE NOT OBSERVED.</p>
 CAUTION	<p>After removing power, allow at least five minutes to elapse and verify that the capacitors have discharged to a safe level before contacting internal components. Connect a DC voltmeter across the capacitor terminals or terminals U1, V1 or V1, W1 and ensure that the voltage is at a safe level.</p>

To aid in troubleshooting, a basic schematic diagram, one enclosed interconnection diagram, and a troubleshooting guide that lists potential problems and solutions are included:

Figure 5-1: Basic Schematic Diagram (p15)

Figure 5-2: Enclosed Interconnection (p16)

Table 7-1: Troubleshooting Guide (p25)

Matrix AP+ Harmonic Filter Field Checks

1. Disconnect all power and remove input power wiring from U1, V1, W1 terminals.
2. Remove VFD drive power connections from filter terminals U2, V2, W2 and any contactor or temperature switch wiring. (For filters using control transformers: remove power fuses on top of transformer.)
3. Visually inspect filter terminals and wiring lugs for signs of heat and corrosion. **Contact factory if any wires appear to be missing or cut!**
4. Inspect the U4, V4, W4 capacitor interconnect terminals and wiring.
5. Visually inspect all capacitors for signs of case deformation, bowing of the top, leaking oil or terminal damage. Note the CAP- # and date code of any damaged capacitors.
6. Using a multi meter set to read 100K ohms check:
 - a. Phase to phase U1-V1-W1-U1 (mechanically activate contactor if present) after reactor and caps charge reading should be about 40K (total equivalent breeder resistance value) and should be the same for each phase. Open circuit or very low readings indicate a problem.
 - b. Phase to chassis U1- case, V1-case, W1- case; low readings indicate a ground fault problem.
7. Ensure the “disconnect” is safe, then wire the utility power to U1, V1, W1.
8. Apply power and verify that proper output voltage is present on U2, V2, and W2.
9. Using a clamp on amp meter read the filter input current:
 - a. Readings will be 0.5 of the capacitor current listed in **Table 3-2: Watt Loss – Matrix AP+ 480V, 60Hz (p6)**. Readings should be the same (+/- 5%) for all phase currents; **contact the factory if currents are out of tolerance!**
 - b. Open contactor readings will show zero current for all phases.
10. Disconnect filter power and wire the VFD to U2, V2, and W2 as well as any control wiring to the filter contactor or temperature switch. Replace any control transformer fuses. Follow the drive power start-up guidelines in the drive manufacturer’s user manual.

Table 7-1: Troubleshooting Guide

PROBLEM:	Line voltage is not present at the filter output terminals.
Possible cause:	Power to the filter is turned off.
Solution:	Turn power on.
Possible cause:	One or more external line fuses are blown.
Solution:	Verify the continuity of line fuses in all phases. Replace as necessary.
PROBLEM:	Full Load Harmonic current distortion exceeds 5% on one or more phases at full load.
Possible cause:	The capacitor assembly has not been connected.
Solution:	Check interconnection of capacitor assembly per the following: Figure 5-1: Basic Schematic Diagram (p15) Figure 5-2: Enclosed Interconnection (p16)
Possible cause:	A capacitor has failed.
Solution:	Inspect the tops of all capacitors for bowing. Replace failed capacitors.
Possible cause:	Source impedance is less than 1.5%.
Solution:	Add a minimum 1.5% impedance line reactor to the filter input.
Possible cause:	Input source voltage harmonic distortion.
Solution:	Identify equipment causing harmonic voltage distortion and add filters as required or accept elevated THVD.
Possible cause:	Line voltage unbalance exceeds 1%.
Solution:	Balance input line voltage to 1% or less.
PROBLEM:	Filter output voltage is not within specification
Possible cause:	Filter input voltage is not within specification.
Solution:	Check the AC input line voltage and verify that it is within tolerance. Refer to the filter service conditions and performance specifications for tolerances.
Possible cause:	Source impedance is out of tolerance.
Solution:	Verify that the source impedance is within tolerance. Refer to the filter service conditions and performance specifications for tolerances.
Possible cause:	Source impedance is out of tolerance.
Solution:	Verify that the source impedance is within tolerance. Refer to the filter service conditions and performance specifications for tolerances.
Possible cause:	One or more Capacitors are damaged.
Solution:	Visually check capacitor top for distortion or doming. Check for shorts or open caps. Replace failed capacitors.
Possible cause:	Drive set up parameter does not allow for input filter
Solution:	Consult drive manufacturer to update set-up to accommodate input filter.
Possible cause:	Input voltage subject to extreme transients such as switching between two voltage sources. Drive faults on over or under voltage.
Solution:	Source switching is not recommended without proper phase synchronizing or allowing reasonable time delay before transfer to new source.

