

## DRIVING POWER QUALITY

Placement of EMI RFI mains filters for VFD applications with MTE matrix filters or reactors.

By Wayne Walcott

The purpose of this application note is to explain the issues related to potential harmonic and (Electromagnetic Compatibility) EMC mitigation and performance problems associated with VFD operation and use of EMI/RFI mains filters. The ultimate goal is to ensure optimum filter performance of both EMI and Harmonic filters when they are used together. Filter placement is critical and is explained to ensure optimum EMI attenuation as well as harmonic current mitigation. For this paper we will focus on where to apply the EMI filter and why.

Abrupt voltage transitions on the output terminals of a variable-frequency drive (VFD) are an inherent source of radiated and conducted Electromagnetic Interference (EMI). These voltage transition times are essentially determined by the rise and fall time of the semiconductor devices used in the inverter section of VFDs. The present tendency among drive manufacturers is to use the fastest “Insulated-Gate-Bipolar-Transistor” (IGBTs) devices available today which have a much lower power loss and higher switching speed.

Unfiltered EMI RFI on input voltage  
And Drive induced Harmonic current

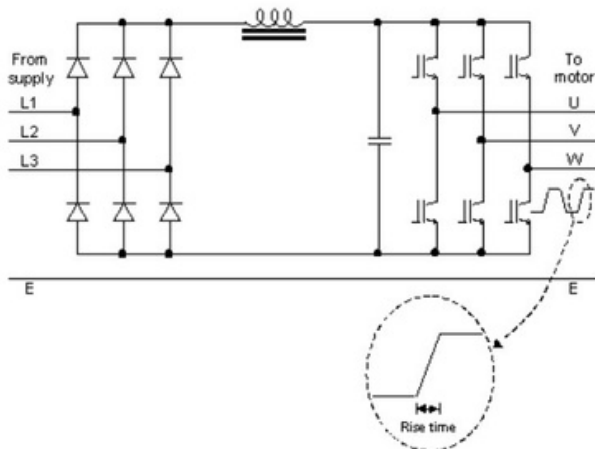
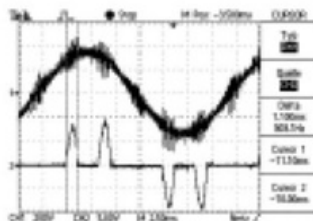

The operating function of VFDs causes high frequency electromagnetic and low frequency harmonic current noise. The high-speed switching of the inverter stage can emit significant radio frequency energy from its input and output wiring. Without mitigation, this energy can interfere with other nearby electrical equipment. EMI-related problems involve a source of noise, coupling of this noise by conduction or radiation, into circuits or equipment that are susceptible to this noise. The origin of noise from VFD operation is high dv/dt pulse-width modulated (PWM) output voltage which drive the motor and couple through stray capacitance to ground of cables and motors insulation resulting in high frequency ground currents, the magnitude of which is determined by the equation  $I = C \, dv/dt$ .

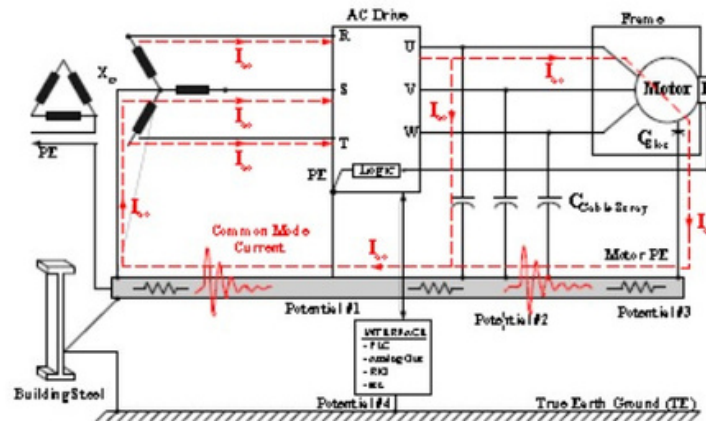

There are two main reasons for employing EMC input filters, namely: (1) to prevent electromagnetic interference of the offending VFD with electronic systems present in close proximity, (2) Governing regulating bodies responsible for policing power quality mandate the installation of appropriate EMC filtering especially in Europe.

Numerous international organizations have been constantly revising standards which have to be considered when designing the EMI filter of a power electronic system. To ensure filter consistent mitigation a test standard for filter qualification is required for certification known as a Line Impedance Stabilizing Network (LISN) and is specified for most of the conducted emission tests in order to guarantee the reproducibility of the measurements. Furthermore, a LISN provides controlled (50 Ohm) impedance between the EMC filters under test, the receiver and the power source.

Using the LISN as a design standard the EMC filter is engineered with a high reactive impedance component to give the best EMI mitigation when measured with the LISN and these tests are usually done on dedicated filters with drives and are not connected to other components or filters.

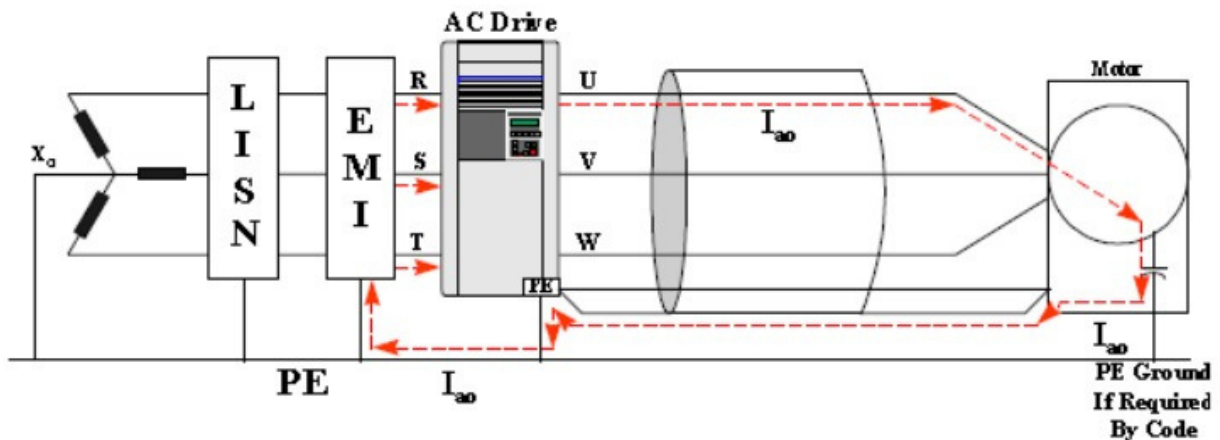

## Typical Three phase EMI RFI Filter circuit

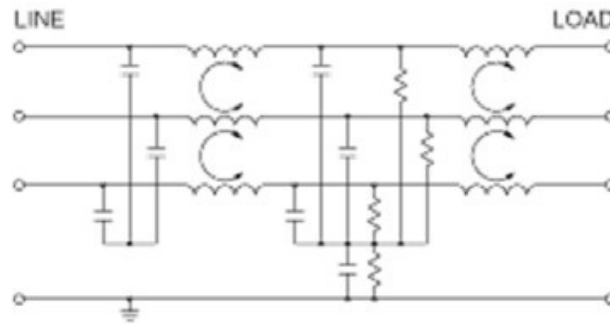

EMC filters are designed so that circuit values for L and C are optimized for lowest power at the fundamental utility frequency and still be able effectively attenuate 50 KHz . The resultant design usually has a high reactive component to its impedance and will be critically damped at about 0.707.

$$\zeta = \frac{L}{2R\sqrt{LC}}$$

An under-damped (< .07) filter may cause ringing or exhibit a tendency to oscillate. An over-damped (>1) lowers the cut off frequency plus it will raise the power loss in the filter.

Because EMC filters are so critically dependent on proper source impedance matching for best performance, placing additional impedance ahead or the EMC filter negates its effectiveness. Furthermore by adding more inductance L and capacitance C from other filters unbalances the EMI filter and will destabilize its critical damping and disable the other filters effectiveness and could cause ringing or oscillations of power to the FVD.

If adding filters causes performance problems how do I use series connected passive filters when I must deal with EMI RFI and drive related current THID harmonics?

*To maintain the proper LISN equivalent source match and acceptable output impedance for the EMC mains filter its input terminals must be directly connected to the utility power (mains). All other passive filters should be connected to the EMC filter output unless the EMI filter was designed with a topology that supports different filter placement.*

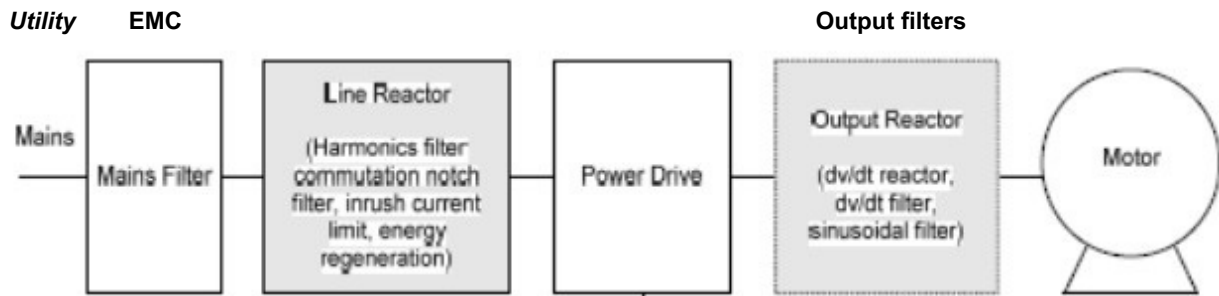
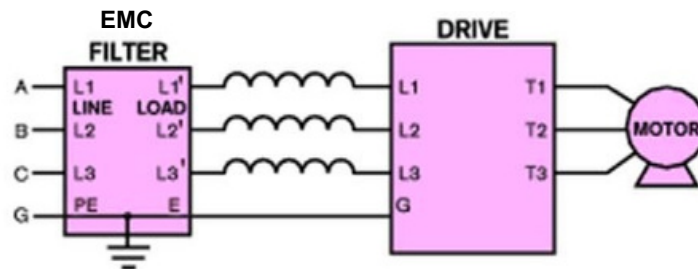

For VFD's that have built in EMC filters and will be used with either a reactor or Matrix filter MTE recommends disabling the drives built in EMC filter or using a drive that does not have a built in EMC filter and adding a separate EMC filter connected to the utility as shown above.

***If the built in EMC remains in circuit adverse harmonic performance and high frequency resonance could develop effecting harmonic mitigation and EMC filter attenuation.***

***The addition of a line reactor at the drive input or load reactor between the drive and motor is shown to significantly improve to EMC attenuation when used with a properly sized and placed EMC filter.***