



POWER QUALITY. SOLVED.
A STEEL PARTNERS COMPANY

dV E-Series

208V – 600V

INSTALLATION GUIDE

FORM: DVT-IG-E
REL. December 2021
REV. 001
© 2021 MTE Corporation

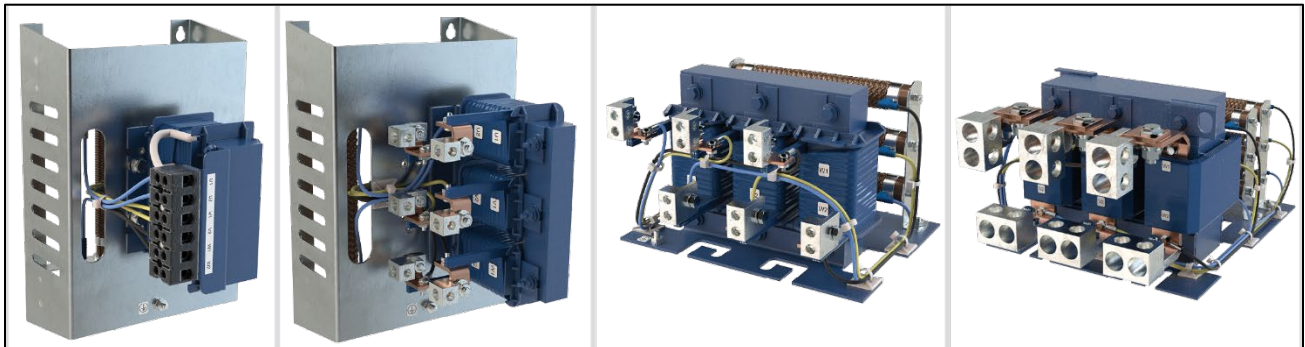

High Voltage! Only a qualified electrician can carry out the electrical installation of this filter.

Quick Reference

1	How to Install	Pages 7 – 12
2	Startup/Troubleshooting	Pages 13 – 16

This page intentionally left blank

TABLE OF CONTENTS

1. WARNINGS	4
WARNINGS AND CAUTIONS	4
PRODUCT SAFETY LABELING	4
GENERAL SAFETY INSTRUCTIONS	5
3. INTRODUCTION	6
RECEIPT & REPAIR STATEMENT	6
WARRANTY	6
4. HOW TO INSTALL	7
INSTALLATION CHECKLIST	7
GROUNDING	8
POWER WIRING CONNECTION	8
BASIC SCHEMATIC DIAGRAM	9
INTERCONNECTION DIAGRAM – KIT	10
INTERCONNECTION DIAGRAM – OPEN PANEL AND ENCLOSED	11
TORQUE RATINGS.....	12
5. START UP	13
SAFETY PRECAUTIONS	13
6. TROUBLESHOOTING	14

List of Figures

Figure 3-1: Basic Schematic Diagram	9
Figure 3-2: Kit Diagram	10
Figure 3-3: Open Panel and Enclosed Diagram	11



List of Tables

Table 3-1: Torque Ratings	12
Table 6-1: Performance Specifications.....	14
Table 6-2: Troubleshooting Guide	15

1. WARNINGS



Warnings and Cautions

The following symbols are used in this manual:



 <p>WARNING</p>	<p>High Voltage Warning: warns of situations that dangerously high voltage is involved. Failure to use proper precautions may lead to serious injury or even death.</p>
 <p>WARNING</p>	<p>General Warning: warns of situations that can result in serious injury or death if proper precautions are not used.</p>
 <p>Caution</p>	<p>General Caution: identifies situations that could lead to malfunction or possible equipment damage.</p>

Product Safety Labeling

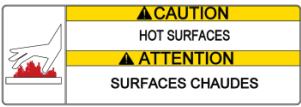
The following labels are placed on the dV E-Series product:

	<p>Label notes to installer to refer to instruction manual first before installing.</p>
	<p>High Voltage: surfaces on product can have high voltage which can cause injury.</p>
	<p>Hot Surfaces: surfaces of product can be hot at times and cause burns.</p>

General Safety Instructions

 WARNING	<p>High Voltage! Only a qualified electrician can carry out the electrical installation of this filter.</p>
	<p>High voltage is used in the operation of this filter. Use extreme caution to avoid contact with high voltage when operating, installing, or repairing this filter. Injury or death may result if safety precautions are not observed.</p>
 WARNING	<p>The opening of the branch circuit protective device may be an indication that a fault current has been interrupted. To reduce the risk of fire or electrical shock, current-carrying parts and other components of the filter should be examined and replaced if damaged.</p>
	<p>An upstream disconnect/protection device must be used as required by the National Electrical Code (NEC) or governing authority.</p>
	<p>Even if the upstream disconnect/protection device is open, the drive downstream of the filter may feedback high voltage to the filter. The drive safety instructions must be followed. Injury or death may result if safety precautions are not observed.</p>
	<p>The filter must be grounded with a grounding conductor connected to all grounding terminals. Modular filters must have reactor grounded through a 2"x2" area cleaned of paint and varnish on lower mounting bracket.</p>
 Caution	<p>Loose or improperly secured connections may damage or degrade filter performance. Visually inspect and secure all electrical connections before power is applied to the filter.</p>
	<p>Wiring should not be routed underneath panel in resistor housing. Doing so could result in fire or damage to the product.</p>
	<p>Product should not be mounted on wood or any other combustible surface. Doing so could lead to fire or damage to the product.</p>

3. INTRODUCTION

The purpose of the manual is to aid in the proper installation of the dV E-Series motor protection filter.

This manual is intended for use by personnel experienced in the operation and maintenance of drives. Because of the high voltages required by the filter, drive, and the potential dangers presented by rotating machinery, it is essential that all personnel involved in the operation and maintenance of this filter know and practice the necessary safety precautions for this type of equipment. Personnel should read and understand the instructions contained in this manual before installing, operating, or servicing the filter and drive to which it is connected.

Receipt & Repair Statement

Upon Receipt of this Filter:

The dV E-Series motor protection filter has been subjected to demanding factory tests before shipment. Carefully inspect the shipping container for damage that may have occurred in transit. Then unpack the filter and carefully inspect for any signs of damage. Save the shipping container for future transport of the filter.

In the event of damage, please contact and file a claim with the freight carrier involved immediately.

If the equipment is not going to be put into service upon receipt, cover and store the filter in a clean, dry location. After storage, ensure that the equipment is dry and that no condensation or dirt has accumulated on the internal components of the filter before applying power.

Repair/Exchange Procedure

MTE Corporation requires a Return Material Authorization Number and form before we can accept any filters that qualify for return or repair. If problems or questions arise during installation, setup, or operation of the filter, please contact MTE for assistance at:

Toll Free: 1-800-455-4MTE (1-800-455-4683)

International Tel: (+1) 262-253-8200



Fax: (+1) 262-253-8222

Warranty

Three years from the date of shipment. See www.mtecorp.com for details.

4. HOW TO INSTALL

Installation Checklist

 WARNING	<p>Prior to installation, please review the safety instructions on pages 1 & 2. Failure to practice this can result in body injury!</p>
	<p>Input and output wiring to the filter should be performed by authorized personnel in accordance with NEC and all local electrical codes and regulations.</p>
 WARNING	<p>The filter is designed for use with copper conductors with a minimum temperature rating of 75 degrees C.</p>

The dV E-Series filters are supplied in the following mechanical configurations:

- Kits (3A-750A): Reactor and resistor are provided separately and are not preassembled or pre-wired.
- Open Panel assemblies (3A-750A): Reactor and resistor are assembled on a panel and pre-wired together.
- Floor mounted general purpose NEMA 1/2 & 3R cabinets (3A - 750A): Reactor and resistor/resistor panel are supplied in a cabinet with all items pre-wired together.

Minimum Required Space:

When determining the internal temperature rise and cooling requirements of the enclosure, include the power dissipation of the filter along with all the other components located in the panel. A general guideline is to allow a side clearance of four (4) inches and a vertical clearance of six (6) inches for proper heat dissipation and access within the enclosure. Clearances may be less if proper ventilation exists. Filter components must operate within temperatures specified in this manual or filter operating life will be compromised. Also, be aware of minimum electrical clearances as defined by the appropriate system safety standard(s). The Kit and Open panel versions of the dV E-Series filters generate heat and should be positioned away from heat sensitive components. Avoid locations where the filter would be subjected to excessive vibrations. Locate the filter as close to the inverter as possible.

General purpose NEMA 1/2 and 3R enclosed filters are designed for floor mounting in an environment suitable for the enclosure type. Do not install in or near a corrosive environment. Avoid locations where the filter would be subjected to excessive vibrations. Allow a minimum side and back clearance of eight (8) inches and front clearance of thirty-six (36) inches for proper heat dissipation and access.

Grounding

 WARNING	The filter must always be grounded with a grounding conductor connected to ground terminals.
	For panel mounted units, ensure a 2" x 2" area is cleaned of paint and varnish on lower mounting bracket for ground connection.

NOTE: For cable shield grounding follow the drive manufacturer’s recommendations.

Power Wiring Connection

 WARNING	Input and output power wiring to the filter should be performed by authorized personnel in accordance with the NEC and all local electrical codes and regulations. Cable lugs and mounting hardware are provided by the customer.
	Any extremely low or high resistance readings indicate miswiring and may result in damage to filter components if not corrected.
	On NEMA 3R enclosures, CAB-26AP and larger, no live parts shall be mounted below 8 inches from the bottom of the enclosure.

Verify that the power source to which the filter is to be connected is in agreement with the nameplate data on the filter. A fused disconnect switch or circuit breaker should be installed between the filter and its source of power in accordance with the requirements of the NEC and all local electrical codes and regulations. Refer to the drive user manual for selection of the correct fuse rating and class.

For part numbers starting with **DVTK**, interconnection between the reactor, resistor, drive, and motor is shown in Figure 3-2: Kit Diagram (p10).

For part numbers starting with **DVTP**, **DVTG**, or **DVTW**, interconnection between the filter, drive, and motor is shown in Figure 3-3: Open Panel and Enclosed Diagram (p11).

Wire gauge range and terminal torque requirements for the dV E-Series are shown in Table 3-1: Torque Ratings (p12).

Refer to the drive user manual for instructions on interconnecting the drive and motor and the correct start-up procedures for the drive.

The filter is designed for use with copper conductors with a minimum temperature rating of 75 degrees C.

Basic Schematic Diagram

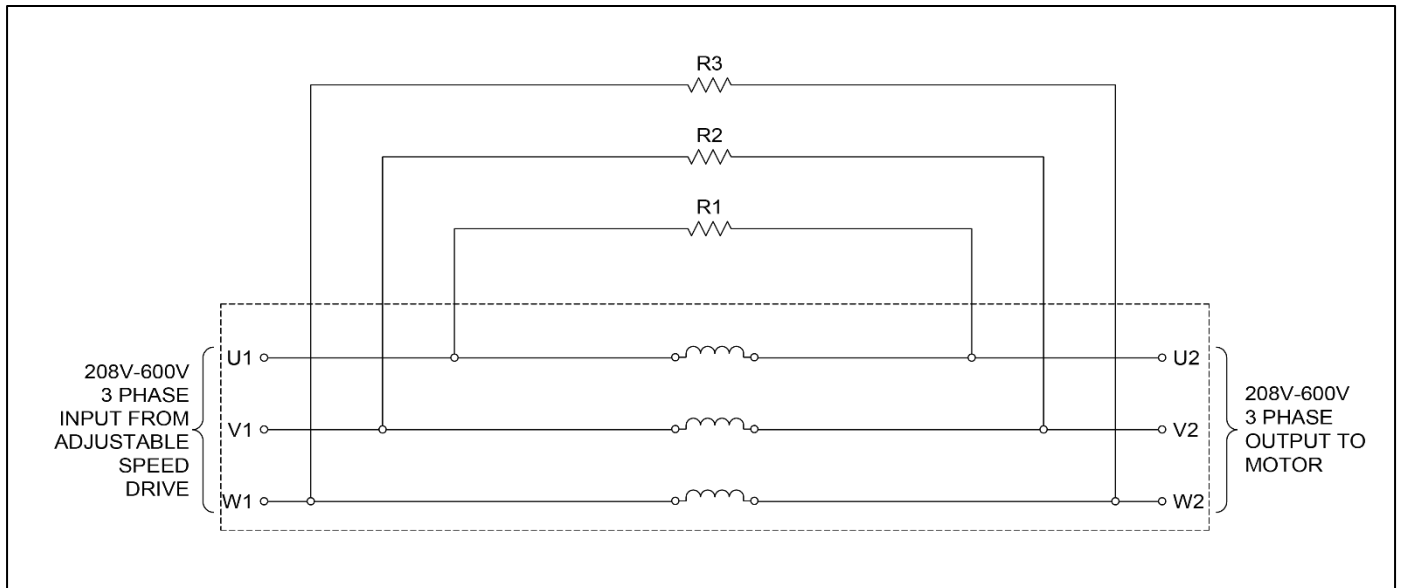

Figure 3-1: Basic Schematic Diagram

Interconnection Diagram – Kit

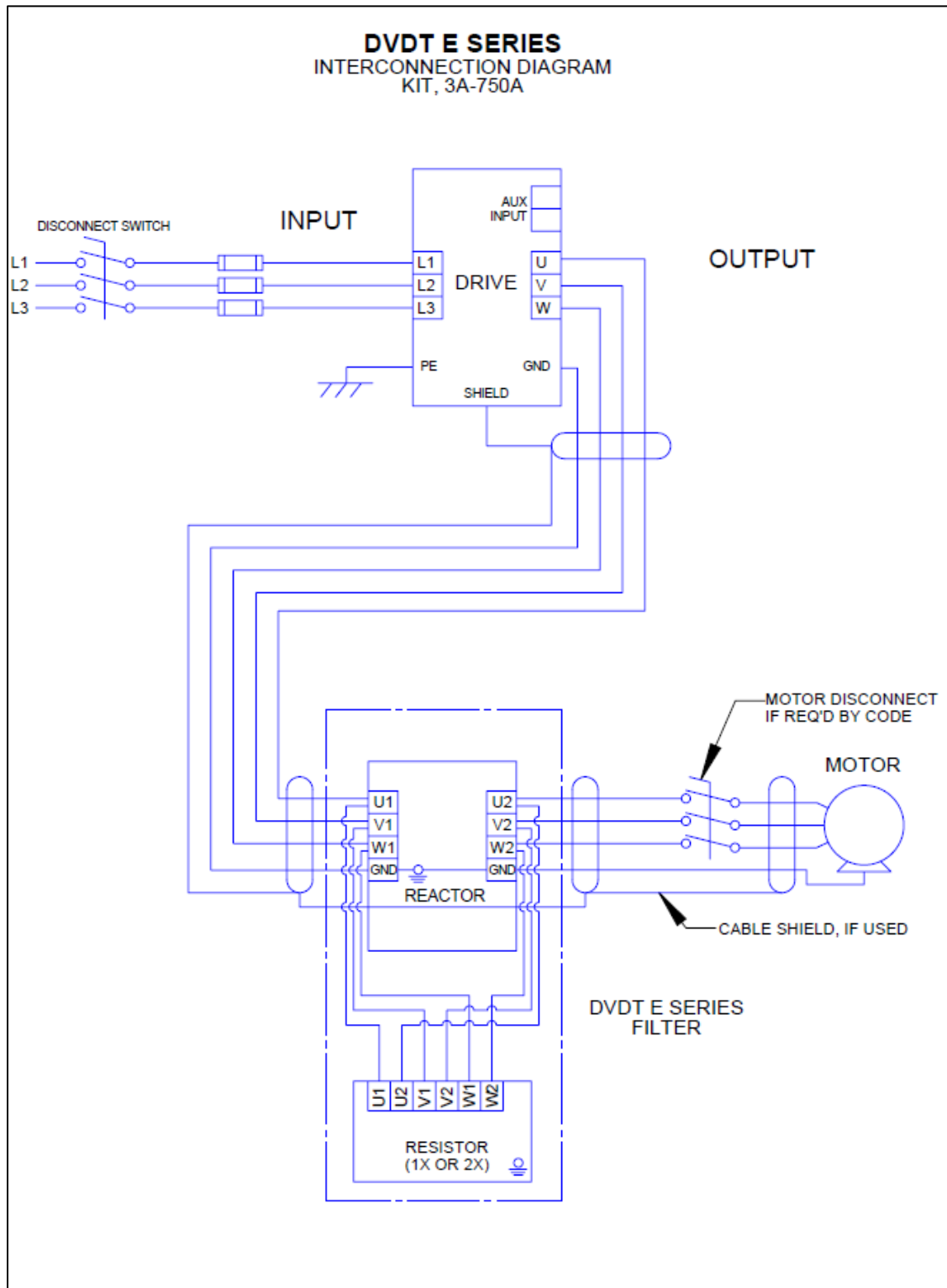

Figure 3-2: Kit Diagram

Interconnection Diagram – Open Panel and Enclosed

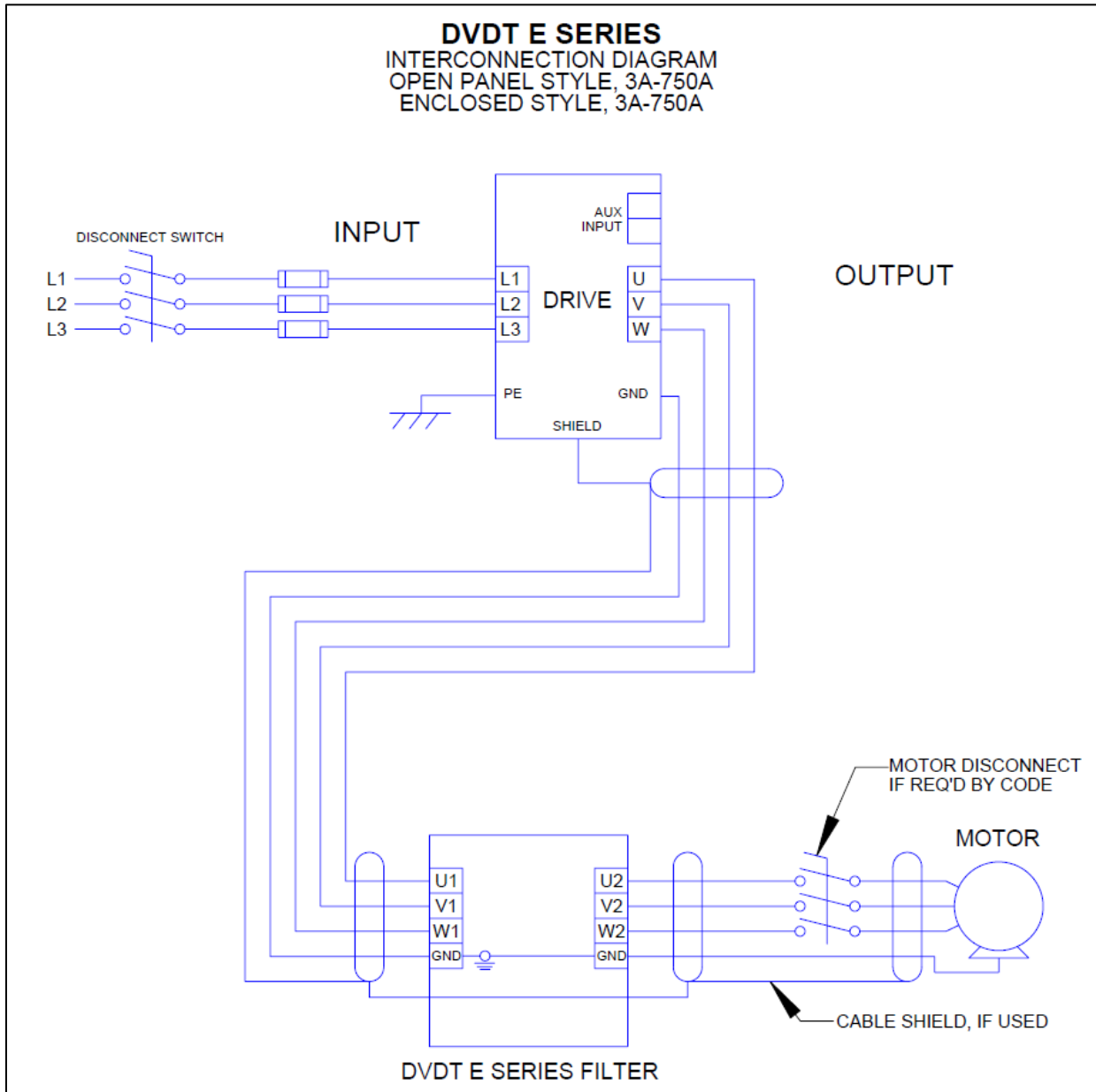

Figure 3-3: Open Panel and Enclosed Diagram

Torque Ratings

Table 3-1: Torque Ratings

Filter Rating (Amps)	dV E-Series Terminals			
	Input /Output Power U1-V1-W1 / U2-V2-W2		Resistor Terminals (Kits ONLY)*	
	Recommended Minimum Wire Size (AWG)	Terminal Torque (in-lbs.)	Recommended Wire Size (AWG)	Terminal Torque (in-lbs.)
3 - 12	14	16	16	N/A
17	12	16	14	N/A
22	10	16	14	N/A
27	10	16	14	N/A
35	8	16	14	N/A
45	8	16	14	N/A
55	6	16	14	N/A
65	6	N/A	14	N/A
80	4	N/A	14	N/A
110	2	N/A	14	N/A
130	1	N/A	14	N/A
160	4(2x) or 2/0	N/A	14	N/A
200	3(2x) or 3/0	N/A	14	N/A
250	1 (2x) or 250kcmil	N/A	14	N/A
305	2/0 (2x)	N/A	14	N/A
365	3/0 (2x)	N/A	14	N/A
415	4/0 (2x)	N/A	14	N/A
515	300kcmil (2x)	N/A	14	N/A
600	350kcmil(2x)	N/A	14	N/A
750		N/A	14	N/A

NOTE: Kit versions of the dV E-Series ship with a reactor and resistor only. Wiring between these components is the responsibility of the customer and should follow the recommended wire size listed above under “Resistor Terminals.” All other versions of the dV E-Series are pre-wired.



NOTE: To prevent flexing or bending of the coil windings attached to dV E-Series filter, use appropriate strain relief to prevent stress on terminals. For flat copper terminal tabs, use two wrenches to tighten customer provided cable mounting hardware.

NOTE: Wiring should be UL 1199, Class N (200° C)

5. START UP

Safety Precautions

Before start-up, observe the following warnings and instructions:

 WARNING	Internal components of the filter are at line potential when the filter is connected to the drive. This voltage is extremely dangerous and may cause death or severe injury if you come in contact with it.
	Use extreme caution to avoid contact with line voltage when checking for power. INJURY OR DEATH MAY RESULT IF SAFETY PRECAUTIONS ARE NOT OBSERVED.
	Damage to equipment or serious injury may occur if the inverter start-up procedures are not observed.
 Caution	Damage to the filter may occur if the appropriate output carrier frequency is not observed.

Sequence of Operation

1. Read and follow safety precautions.
2. After installation, ensure that:
 - All filter ground terminals are connected to ground.
 - Power wiring to the utility, drive, filter, and motor is in accordance with the power wiring connection diagrams shown in installation instructions section.
3. Check that moisture has not condensed on the filter components. If moisture is present, do not proceed with start-up until the moisture has been removed.
4. Disconnect filter output terminals from the motor.
5. Set the drive switching frequency to the appropriate setting.
 - 2kHz – 4kHz (3A – 750A Filters)
6. Connect filter temperature safety overload switch into the control circuit so that the drive will shut down in an overload situation.
7. Confirm that drive voltage is present at the input terminals (U1, V1, W1) of the filter.
8. Confirm that drive voltage is present at the output terminals (U2, V2, W2) of the filter.
9. Connect the filter output to the motor.
10. Refer to the drive user manual for the drive start-up procedure. Observe all safety instructions in the drive user manual.

6. TROUBLESHOOTING

 WARNING	<p>When properly installed, this equipment has been designed to provide maximum safety for operating personnel.</p> <p>However, hazardous voltages and elevated temperatures exist within the confines of the enclosure. Servicing should therefore be performed by qualified personnel only and in accordance with OSHA Regulations.</p>
	<p>High voltage is used in the operation of this filter. Use Extreme caution to avoid contact with high voltage when operating, installing, or repairing this filter. INJURY OR DEATH MAY RESULT IF SAFETY PRECAUTIONS ARE NOT OBSERVED.</p>

To aid in troubleshooting, a basic schematic diagram, two interconnection diagrams, and a troubleshooting guide that lists potential problems and solutions are included:

Figure 3-1: Basic Schematic Diagram (p9)

Figure 3-2: Kit Diagram (p10)

Figure 3-3: Open Panel and Enclosed Diagram (p11)

Table 6-2: Troubleshooting Guide (p15)

For specific product performance specifications, reference Table 6-1 below:

Table 6-1: Performance Specifications

Voltage	208V - 600V +/- 10%; 60Hz
Inverter Operating Frequency	0 – 60Hz without derating
Maximum Ambient Temperature	-40C to +60C Modular Filter
	-40C to +50C Enclosed Filter
	-40C to +90C Storage
Insulation System	Class N (200° C)
Insertion Loss (Voltage)	1.7% @ 60Hz
Efficiency	>99%
Altitude without derating	6,600 feet above sea level
Maximum Motor Lead Length	1,000 feet (VFD rated cable recommended)
Relative Humidity	0% to 99% non-condensing
Current Rating	100% RMS Continuous; 150% for 1 minute; 200% for 10 sec *Operating in overload will result in increased proportional voltage drop
Rise Time	Greater than 0.1 uS
Peak Voltage @ Motor	150% of DC bus voltage up to 1,000 feet

Table 6-2: Troubleshooting Guide

PROBLEM: Voltage is not present at the filter input terminals.	
Possible cause:	Power to the filter is turned off or shut down.
Solution:	Turn power on; check drive errors.
Possible cause:	One or more external line fuses are blown.
Solution:	Verify the continuity of line fuses in all phases. Replace as necessary.
Possible cause:	Damage to drive – dV E-Series interconnect cables.
Solution:	Replace damaged cables.
Possible cause:	Drive setup parameters are incorrect.
Solution:	Verify motor current, voltage, and shutdown parameters are valid.
PROBLEM: dV E-Series filter runs Hot	
Possible cause:	Normal operation, reactor > 150° C and resistors > 300° C.
Solution:	Caution: Parts are very hot and may cause burns. Follow installation guidelines for clearance and check for adequate air flow.
Possible cause:	Motor coil damage: windings shorted.
Solution:	Replace motor; inspect wiring.
Possible cause:	Heat buildup within enclosure.
Solution:	Provide clearance and venting for filter components.
Possible cause:	Heat buildup within enclosure.
Solution:	Check carrier frequency and overload settings.
Possible cause:	Multiple motor applications create complex loading and resonances with dV E-Series filter.
Solution:	dV E-Series filters can be paralleled for higher current ratings. Contact MTE Application Engineering for more information.

This page intentionally left blank